



**ENGINEERING TRAINING  
SUPPLEMENT**

**No. 3**

**ISSUE 2**

**HARMONIC DISTORTION AND NEGATIVE  
FEEDBACK IN AUDIO-FREQUENCY AMPLIFIERS**

**BRITISH BROADCASTING CORPORATION**

**ENGINEERING TRAINING  
SUPPLEMENT**

**No. 3**

**ISSUE 2**

**HARMONIC DISTORTION AND NEGATIVE  
FEEDBACK IN AUDIO-FREQUENCY AMPLIFIERS**

**Issued by  
ENGINEERING TRAINING DEPARTMENT  
BBC**

**December, 1950**

*Reprinted by Rotaprint December 1956*

## **PREFACE TO SECOND EDITION**

In this revised edition the principal changes are in the sections dealing with the effects of negative feedback on amplifier performance and with the effects of series- and parallel-connected feedback on input impedance. Additions have been made to the section on combined voltage and current feedback.

The reduction of gain, noise and distortion by negative feedback are dealt with as separate properties and in the treatment of parallel-connected feedback a distinction is drawn between the value of  $\beta$  which affects gain and that which affects input impedance.

All symbols have been brought into line with the recommendations of the British Standards Institution as set out in publication 1409 : 1947, *Letter Symbols for Electronic Valves*.

# HARMONIC DISTORTION

## SINUSOIDAL WAVEFORMS

Any complex recurrent waveform may be regarded as the resultant of a number of components of sinusoidal waveform. Thus the sine wave is the basic waveform.

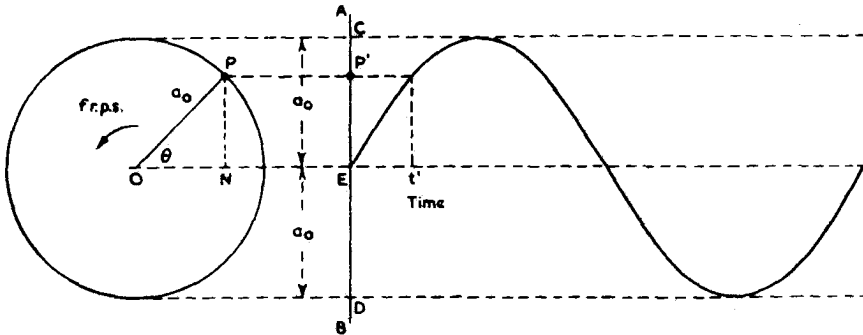

Fig. 1. Graphical Method of Generating a Sine Wave

A sine curve and a graphical method of generation are illustrated in Fig. 1.

Imagine the point  $P$  to move round the circumference of the circle of radius  $OP$  in an anti-clockwise direction (the conventional positive direction), at the rate of  $f$  revolutions per second. The number of radians,  $\theta$ , described by  $OP$  during a time  $t$  is given by  $\theta = 2\pi ft$ . This is usually written  $\theta = \phi t$ , where  $\phi = 2\pi f$  = the angular velocity of  $OP$  in radians per second.  $P'$  is the projection of  $P$  on the line  $AB$  and as the line  $OP$  rotates about  $O$ ,  $P'$  moves up and down  $AB$  between the limits  $CD$ . To the right of  $AB$  a curve is plotted showing the position of  $P'$  at various times during one complete revolution of  $P$ . This curve is a sine function, and  $CE$  the peak value or amplitude,  $a_0$ . At a particular instant  $t'$  the distance  $P'E$  is given by  $a_0 \sin \theta$  and since  $\theta = \phi t'$ ,  $P'E = a_0 \sin \phi t'$ . In general the displacement,  $a$ , of the sine curve is given by  $a = a_0 \sin \phi t$ . The horizontal axis of Fig. 1 may be calibrated in terms of angles, fractions of a cycle or (if the frequency is known) in seconds. The expression  $a = a_0 \sin \phi t$  applies to all sinusoidal oscillations or simple harmonic motions.

Thus an alternating current,  $I$ , may be expressed as  $I = I_{pk} \sin \phi t$ , and an alternating voltage,  $V$ , as  $V = V_{pk} \sin \phi t$ , where  $I_{pk}$  and  $V_{pk}$  represent peak values; in both expressions the frequency is  $\phi/2\pi$  cycles per second.

## DYNAMIC CHARACTERISTICS

### Linear Dynamic Characteristics

In an ideal valve the anode current,  $I_a$ , is a linear function of the grid

## HARMONIC DISTORTION

potential,  $V_g$ . This may be expressed thus:—

$$I_a = a_o + bV_g \dots \dots \dots (1)$$

where  $a_o$  = anode current when  $V_g = 0$  (see Fig. 2), and  $b$  = mutual conductance ( $g_m$ ) of the valve.

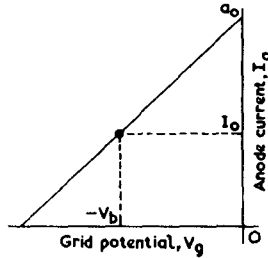

Fig. 2. Linear  $I_a - V_g$  Characteristic

If  $V_g$  is the resultant of a constant negative-bias component,  $-V_b$ , and an input-signal component,  $V_{pk} \sin pt$ , then

$$V_g = -V_b + V_{pk} \sin pt$$

and, substituting for  $V_g$  in equation (1),

$$I_a = (a_o - bV_b) + bV_{pk} \sin pt \dots \dots (2)$$

Let  $a_o - bV_b = I_o$  where  $I_o$  is the anode current when  $V_{pk} = 0$  (see Fig. 2), i.e., the anode current with grid bias applied to the valve and zero signal input.

Then,

$$I_a = I_o + bV_{pk} \sin pt \dots \dots (3)$$

This expression contains only one alternating component and this component is of fundamental frequency,  $p/2\pi$  cycles per second; no harmonics are introduced and amplification is distortionless.

### Parabolic Dynamic Characteristics.

In practice the  $I_a - V_g$  curve of a valve is not perfectly straight and its shape may be deduced by considering the lengths of the intercepts made by the  $I_a - V_a$  characteristics with the load line. For example, consider Fig. 3, which shows a load line superimposed upon the  $I_a - V_a$  curves of a triode valve. The lengths of the intercepts are greater at small values of  $V_g$  than for

## HARMONIC DISTORTION

large negative values. If the valve is biased at  $-30$  volts the output signal is asymmetrical, one half-cycle having a larger amplitude than the other. This effect is typical of a dynamic  $I_a - V_g$  characteristic with parabolic curvature, i.e., one obeying the equation

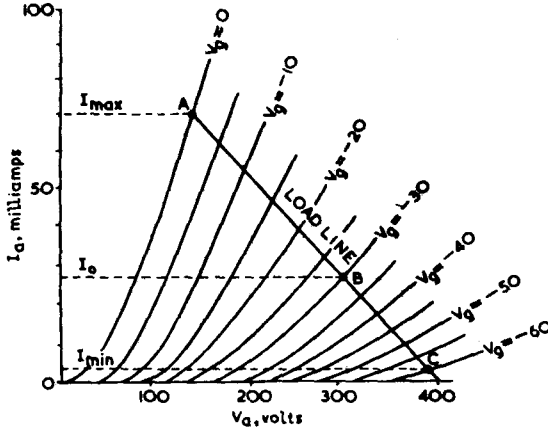

Fig. 3. Load Line Superimposed on a Set of Triode  $I_a - V_a$  Curves

$$I_a = a_0 + bV_g + cV_g^2 \dots \dots \dots (4)$$

where  $a_0$  = anode current when  $V_g = 0$ ,  
 $b$  = mutual conductance at  $V_g = 0$ ,  
 $c$  = a constant, numerically small compared with  $b$ . When the intercepts made on the load line by the  $I_a - V_a$  curves become larger as  $V_g$  is decreased negatively towards zero (see Fig. 3), the constant  $c$  is positive in sign.

If  $V_g = -V_b + V_{pk} \sin pt$ , then, substituting in equation (4),

$$\begin{aligned} I_a &= a_0 + b(-V_b + V_{pk} \sin pt) + c(-V_b + V_{pk} \sin pt)^2 \\ &= a_0 + b(-V_b + V_{pk} \sin pt) + c(V_b^2 - 2V_b V_{pk} \sin pt + V_{pk}^2 \sin^2 pt) \\ &= (a_0 - bV_b + cV_b^2) + (b - 2cV_b) V_{pk} \sin pt + cV_{pk}^2 \sin^2 pt \\ &= (a_0 - bV_b + cV_b^2) + (b - 2cV_b) V_{pk} \sin pt + \frac{cV_{pk}^2}{2} (1 - \cos 2pt) \end{aligned}$$

## HARMONIC DISTORTION

$$= (a_0 - bV_b + cV_b^2 + \frac{cV_{pk}^2}{2}) + (b - 2cV_b) V_{pk} \sin pt + \frac{cV_{pk}^2}{2} \sin (2pt - \frac{\pi}{2}) \dots \dots \dots (5)$$

Let  $a_0 - bV_b + cV_b^2 = I_0$  where  $I_0$  is the anode current when  $V_{pk} = 0$ , i.e., the anode current with grid bias  $V_b$  applied to the valve and zero signal input.

Then,

$$I_a = (I_0 + \frac{cV_{pk}^2}{2}) + (b - 2cV_b) V_{pk} \sin pt + \frac{cV_{pk}^2}{2} \sin (2pt - \frac{\pi}{2}) \dots (6)$$

$$\text{Let } I_0 + \frac{cV_{pk}^2}{2} = I_{mean}$$

where  $I_{mean}$  = d.c. component of anode current with grid bias and the signal applied. Then

$$I_a = I_{mean} + (b - 2cV_b) V_{pk} \sin pt + \frac{cV_{pk}^2}{2} \sin (2pt - \frac{\pi}{2}) \dots \dots (7)$$

The first of the three terms on the right-hand side of equation (7) represents a d.c. component. The second represents an a.c. component at the fundamental frequency  $p/2\pi$  cycles per second and is the wanted output signal. The third is a term with twice the frequency of the applied signal and is an unwanted second-harmonic component; it is the term which is responsible for asymmetry in the output waveform.

From the expression for the second-harmonic component,

$$\frac{1}{2} cV_{pk}^2 \sin (2pt - \pi/2)$$

it is clear, since  $c$  is positive, that the phase of the second-harmonic component is displaced from the fundamental by 90 degrees in terms of the second-harmonic term, which is equal to 45 degrees in terms of the fundamental term.

Curves of the fundamental and second-harmonic term with this phase displacement are given by dotted lines in Fig. 4 and their sum is shown by the full line. This illustrates clearly the asymmetrical nature of the waveform given by a parabolic dynamic characteristic.

The anode current under no-signal conditions is  $I_0$ . With the signal applied it increases to  $I_{mean} = I_0 + \frac{1}{2}cV_{pk}^2$ . This increase in the d.c. component of anode current with the application of the signal may be taken as an indication of the presence of second-harmonic distortion and, if no even-order terms higher than  $V_g^2$  are present in the expression for the valve characteristic (equation 4), the increase is equal to the peak value of the second-harmonic current component.

## HARMONIC DISTORTION

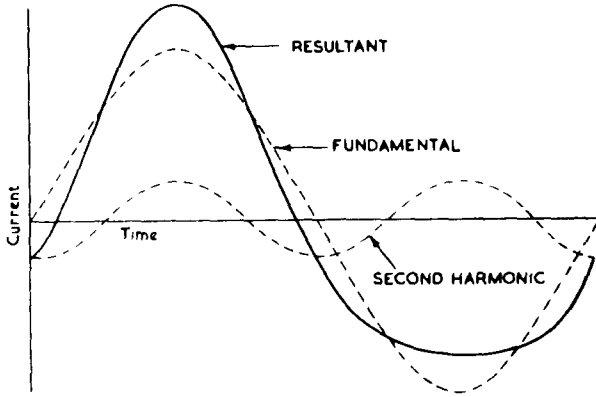

Fig. 4. Effect of adding a Second-harmonic Term to a Sinusoidal Waveform

### Method of Determining the Second-harmonic Distortion given by a Parabolic Characteristic

Second-harmonic distortion is usually assessed by the quotient

$$\frac{\text{amplitude of second harmonic component}}{\text{amplitude of fundamental component}}$$

and is generally expressed as a percentage. Hence, percentage of second-harmonic distortion

$$\begin{aligned}
 &= 100 \times \frac{\text{amplitude of second harmonic component}}{\text{amplitude of fundamental component}} \\
 &= 100 \times \frac{cV_{pk}^2/2}{V_{pk}(b - 2cV_b)} = 50 \frac{cV_{pk}}{(b - 2cV_b)} \text{ per cent.} \quad \dots (8)
 \end{aligned}$$

This expression shows that the second-harmonic distortion produced is directly proportional to the amplitude of the input signal,  $V_{pk}$ .

It is not convenient to evaluate the distortion from this expression, because the values of the constants  $b$  and  $c$  are not often known. From this result, however, it is possible to deduce an expression for the distortion in terms of the maximum, minimum and either the mean or the no-signal currents of a valve. These values can conveniently be obtained by examination of the  $I_a - V_a$  characteristics and the load line.



## HARMONIC DISTORTION

Fig. 5 shows a parabolic  $I_a - V_g$  characteristic, a sinusoidal input signal voltage and the resulting anode-current waveform. This has the same shape as the solid curve in Fig. 4.

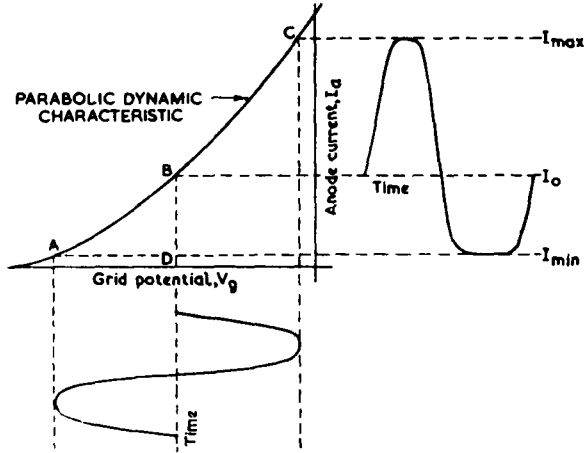

Fig. 5. Waveform Distortion produced by a Parabolic  $I_a - V_g$  Dynamic Characteristic

The anode-current waveform of Fig. 5 may be analysed as shown in Fig. 6. Here  $I_0$  indicates the anode current in the absence of an alternating input signal and the solid curve indicates the anode-current waveform when the input signal is applied. This waveform may be resolved into a fundamental component of amplitude  $I_1$ , a second-harmonic component of amplitude  $I_2$  and a d.c. component of value  $I_{mean}$ . As shown,  $I_{mean}$  is greater than  $I_0$  and the difference is equal to  $I_2$ .

*Second-harmonic Distortion in Terms of  $I_{max}$ ,  $I_{min}$  and  $I_{mean}$ .*

From Fig. 6

$$I_{max} = I_{mean} + I_1 + I_2 \quad \dots \quad \dots \quad \dots \quad (9)$$

$$I_{min} = I_{mean} - I_1 + I_2 \quad \dots \quad \dots \quad \dots \quad (10)$$

Adding (9) and (10)

$$I_{max} + I_{min} = 2I_{mean} + 2I_2$$

$$\therefore 2I_2 = I_{max} + I_{min} - 2I_{mean} \quad \dots \quad \dots \quad (11)$$

Subtracting (10) from (9)

$$I_{max} - I_{min} = 2I_1$$

$$\therefore 2I_1 = I_{max} - I_{min} \quad \dots \quad \dots \quad (12)$$

## HARMONIC DISTORTION

From (11) and (12)

$$\frac{\text{amplitude of second harmonic component}}{\text{amplitude of fundamental}} = \frac{I_2}{I_1}$$

$$= \frac{I_{max} + I_{min} - 2I_{mean}}{I_{max} - I_{min}} \dots \dots \dots (13)$$

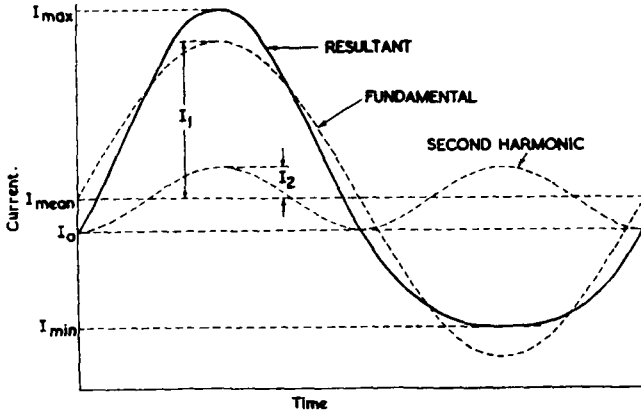

Fig. 6. Determination of Second-harmonic Content

Hence the percentage of second-harmonic distortion is given by

$$100 \left( \frac{I_{max} + I_{min} - 2I_{mean}}{I_{max} - I_{min}} \right) \dots \dots \dots (14)$$

*Second-harmonic Distortion in Terms of  $I_{max}$ ,  $I_{min}$  and  $I_0$ .*

Since  $I_{mean} = I_0 + I_2$  equation (11) may be written

$$2I_2 = I_{max} + I_{min} - 2(I_0 + I_2)$$

from which

$$4I_2 = I_{max} + I_{min} - 2I_0 \dots \dots \dots (15)$$

Dividing (15) by (12)

$$\frac{\text{amplitude of second harmonic component}}{\text{amplitude of fundamental}} = \frac{I_2}{I_1}$$

## HARMONIC DISTORTION

$$= \frac{I_{max} + I_{min} - 2I_o}{2(I_{max} - I_{min})} \dots \dots \dots (16)$$

Hence the percentage of second-harmonic distortion is given by

$$50 \left( \frac{I_{max} + I_{min} - 2I_o}{I_{max} - I_{min}} \right) \dots \dots \dots (17)$$

### Position of the Quiescent Point on the Load Line

The percentage of second-harmonic distortion can be related to the ratio  $AB : AC$  in Fig. 3, as follows :—

Let  $AB : AC = r : 1$ , i.e., let

$$I_{max} - I_o = r(I_{max} - I_{min})$$

From equation (17), the percentage of second-harmonic distortion

$$= 100 \left[ \frac{(I_{max} - I_o) - (I_o - I_{min})}{2(I_{max} - I_{min})} \right] \dots \dots \dots (18)$$

On substituting  $(I_{max} - I_o) = r(I_{max} - I_{min})$  in (18), the percentage of second-harmonic distortion becomes

$$= 100 \left[ \frac{r(I_{max} - I_{min}) - (I_o - I_{min})}{2(I_{max} - I_{min})} \right] \dots \dots \dots (19)$$

$$\begin{aligned} \text{Now, } I_o - I_{min} &= (I_{max} - I_{min}) - (I_{max} - I_o) \\ &= (I_{max} - I_{min}) - r(I_{max} - I_{min}) \\ &= (1 - r)(I_{max} - I_{min}) \end{aligned}$$

Substituting this expression in (19) and simplifying, the percentage of second-harmonic distortion

$$\begin{aligned} &= 100 \left[ \frac{r - (1 - r)}{2} \right] \\ &= 100 \left( \frac{2r - 1}{2} \right) \dots \dots \dots (20) \end{aligned}$$

The value of this function is plotted in Fig. 7 for values of  $r$  between 0.3 and 0.5.

## HARMONIC DISTORTION

This graph shows that, if the second-harmonic distortion is to be less than 2 per cent. (sometimes quoted as the maximum permissible value), the value of  $r$  must be less than 0.48. For this value of  $r$ , the quiescent

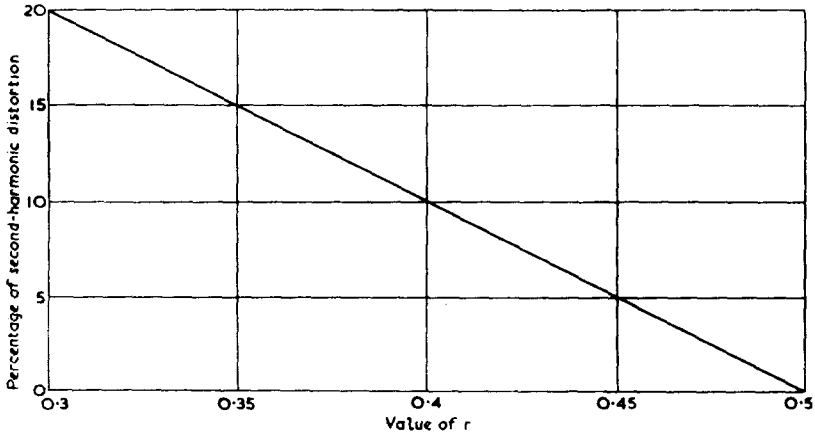

Fig. 7. Relationship between Percentage of Second-harmonic Distortion and  $r = (I_{max} - I_0) / (I_{max} - I_{min})$

point B, Fig. 3, divides the load line internally in the ratio 13 : 12.

In the following table are listed a few values of  $r$  together with the corresponding percentages of second-harmonic distortion and the division ratios in which the quiescent point internally divides the load line.

<i>Value of <math>r</math></i>	<i>Percentage of second harmonic distortion</i>	<i>Ratio in which the quiescent point divides the load line</i>
0.30	20	7 : 3
0.40	10	3 : 2
0.45	5	11 : 9
0.48	2	13 : 12
0.49	1	51 : 49
0.50	0	1 : 1

The relationship between the percentage of second-harmonic distortion and the ratio in which the quiescent point divides the load line makes it possible to prepare a direct-reading harmonic scale which may be superimposed on a load line drawn on a set of  $I_a - V_a$  characteristic curves. The method of construction of such a scale is described elsewhere.\*

\*K. R. Sturley, *Radio Receiver Design*, Part II. Chapman & Hall.

## HARMONIC DISTORTION

### Effect of Phase Displacement of Harmonic Components

The shape of a complex wave depends on the number and amplitude of the harmonic components present and on the relative phases of the components. By altering the phase relationship between the components it is possible to produce different waveforms all of which have the same number and amplitude of components. The human ear cannot, however, distinguish between such waveforms provided they are continuous although it can detect any sudden change in phase.

Figs. 4 and 8 are examples of different waveforms built up from the same two components.

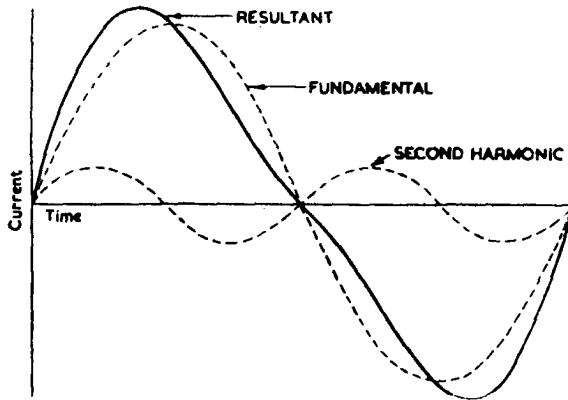

Fig. 8. Effect of Adding a Second-harmonic Term in Phase with a Sinusoidal Waveform

### Cubic Dynamic Characteristics

The  $I_a - V_a$  characteristics of a pentode valve are illustrated in Fig. 9. The intercepts made by the valve curves with the load line are smaller at the ends of the load line than at the middle, showing the presence of third-harmonic distortion. It will also be noted that the points where the intercepts begin to close up are not equidistant from the quiescent point; this denotes the presence of second-harmonic distortion. The dynamic  $I_a - V_a$  curve of a pentode is shown in Fig. 10, and to represent this curve with reasonable accuracy, it is necessary to use a cubic expression, such as

$$I_a = a_0 + b V_g + c V_g^2 + d V_g^3 \quad \dots \quad (21)$$

where  $a_0 = I_a$  when  $V_g = 0$

$b =$  mutual conductance at  $V_g = 0$

$c =$  a constant, small compared with  $b$

$d =$  a constant, small compared with  $c$ .

## HARMONIC DISTORTION

In equation (21) the constant  $c$  is negative. This constant is largely responsible for the changes in slope of the dynamic characteristic (Fig. 10), at small negative values of  $V_g$ . If  $c$  were positive the slope of the curve

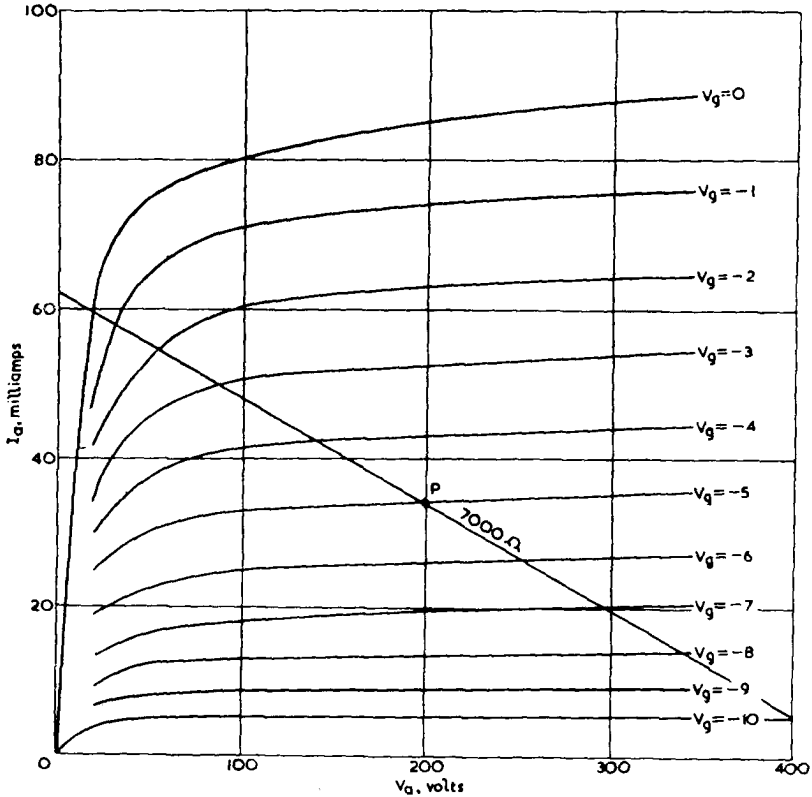

Fig. 9. Load Line Superimposed on a Set of Pentode  $I_a - V_a$  Curves

would increase as  $V_g$  approaches zero as, for example, in the parabolic curve of Fig. 5. The constant  $d$  is also negative. This constant is largely responsible for the changes in slope of the dynamic characteristic at small values of  $I_a$ . If  $d$  were positive the slope of the curve would increase as  $V_g$  is increased negatively towards the value which gives anode-current cut-off in Fig. 10.

If  $V_g = -V_b + V_{pk} \sin pt$ , then, substituting in equation (21),

$$I_a = a_0 + b(-V_b + V_{pk} \sin pt) + c(-V_b + V_{pk} \sin pt)^2 + d(-V_b + V_{pk} \sin pt)^3 \dots \dots \dots (22)$$

## HARMONIC DISTORTION

Expanding the right-hand side of equation (22), collecting terms and simplifying,

$$\begin{aligned}
 I_a = & \left( a_0 - bV_b + cV_b^2 - dV_b^3 + \frac{cV_{pk}^2}{2} - \frac{3dV_bV_{pk}^2}{2} \right) \\
 & + (b - 2cV_b + \frac{3dV_{pk}^2}{4} + 3dV_b^2) V_{pk} \sin pt \\
 & + \left( \frac{c}{2} - \frac{3dV_b}{2} \right) V_{pk}^2 \sin \left( 2pt - \frac{\pi}{2} \right) - \frac{dV_{pk}^3}{4} \sin 3pt \quad (23)
 \end{aligned}$$

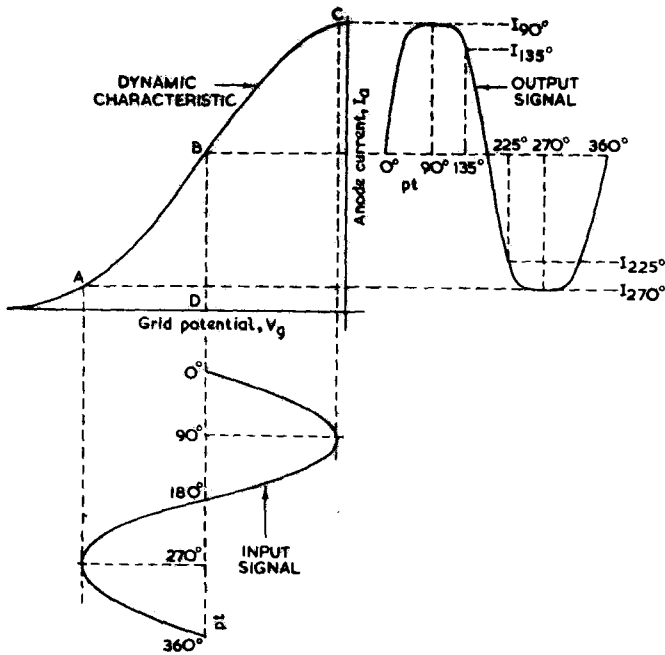

Fig. 10. Waveform Distortion produced by a Cubic  $I_a - V_g$  Dynamic Characteristic

Let  $a_0 - bV_b + cV_b^2 - dV_b^3 = I_0$ .  $I_0$  is the anode current when  $V_{pk} = 0$ , i.e., the anode current with grid bias applied to the valve but zero signal input.

## HARMONIC DISTORTION

Then,

$$\begin{aligned}
 I_a = & \left( I_o + \frac{cV_{pk}^2}{2} - \frac{3dV_b V_{pk}^2}{2} \right) \\
 & + \left( b - 2cV_b + \frac{3dV_{pk}^2}{4} + 3dV_b^2 \right) V_{pk} \sin pt \\
 & + \left( \frac{c}{2} - \frac{3dV_b}{2} \right) V_{pk}^2 \sin \left( 2pt - \frac{\pi}{2} \right) - \frac{dV_{pk}^3}{4} \sin 3pt \quad \dots \quad (24)
 \end{aligned}$$

The first of the four terms on the right hand side of equation (24) represents a d.c. component, the second a component of fundamental frequency, the third a second-harmonic component and the fourth a third-harmonic component

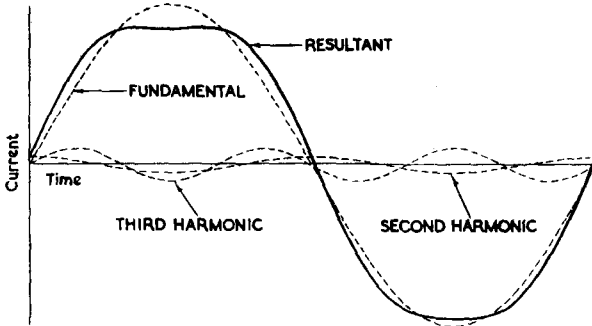

Fig. 11. The Fundamental, Second-harmonic and Third-harmonic Components and the Resultant Waveform produced by a Cubic Characteristic

The phase relationship between the fundamental and the two harmonic components is shown in Fig. 11. The signs against the second- and third-harmonic terms in equation (24) might suggest that the phases of these components are opposite to those shown in Fig. 11, but, as already stated, the constants  $c$  and  $d$  are both negative.

The second-harmonic component is responsible for asymmetry in the resultant waveform. The third-harmonic component does not produce asymmetry but distorts the resultant waveform by flattening both peaks. This can be more readily appreciated by reference to Fig. 12 in which fundamental and third-harmonic components only are shown and the resultant waveform, although distorted, is symmetrical about the time axis. In Fig. 11, where the second-harmonic component is included, both peaks are flattened but the resultant waveform is asymmetrical.



## HARMONIC DISTORTION

The d.c. component of anode current is greater than the no-signal value,  $I_o$ , by an amount equal to the amplitude of the second-harmonic component. The presence of the third-harmonic component does not

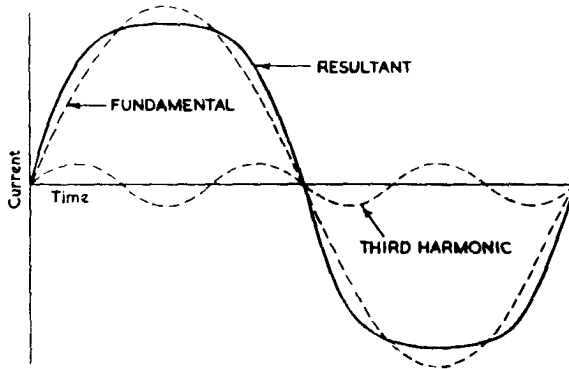

Fig. 12. Effect of Adding a Third-harmonic Term in Phase with a Sinusoidal Waveform

affect the magnitude of the d.c. component so that a direct-current meter in the anode circuit cannot be used to indicate third-harmonic distortion.

The amplitude of the second-harmonic component is given by the expression

$$\left( \frac{c}{2} - \frac{3dV_b}{2} \right) V_{pk}^2$$

Equating this to zero

$$c = 3dV_b$$

showing that if  $c = 3dV_b$  there is no second-harmonic distortion.

The values of  $c$  and  $d$  depend on the anode load and by correct choice of load and of grid bias it is possible to satisfy this condition. The practical significance is that the dynamic curve is made symmetrical about its centre by suitable choice of load and the quiescent point is placed at the centre of the curve by suitable adjustment of grid bias.

### Method of Determining the Third-harmonic Distortion given by a Cubic Characteristic

Let the amplitudes of the fundamental, second-harmonic and third-harmonic components be  $a_1$ ,  $a_2$  and  $a_3$ , respectively. Let the d.c. component be  $I_{mean}$ . Then equation (24) may be written in the form,

## HARMONIC DISTORTION

$$I_a = I_{mean} + a_1 \sin pt + a_2 \sin \left(2pt - \frac{\pi}{2}\right) + a_3 \sin 3pt \dots \dots (25)$$

$$\text{where } I_{mean} = \left( I_o + \frac{cV_{pk}^2}{2} - \frac{3dV_b V_{pk}^2}{2} \right)$$

$$a_1 = \left( b - 2cV_b + \frac{3dV_{pk}^2}{4} + 3dV_b^2 \right) V_{pk}$$

$$a_2 = \left( \frac{c}{2} - \frac{3dV_b}{2} \right) V_{pk}^2$$

$$a_3 = - \frac{dV_{pk}^3}{4}$$

The percentage of third-harmonic distortion is given by  $\frac{100 a_3}{a_1}$  and the values of  $a_1$  and  $a_3$  may be determined as follows :

$$\text{When } pt = 90^\circ, I_a = I_{mean} + a_1 - a_2 - a_3 = I_{90^\circ} \dots \dots (26)$$

$$pt = 135^\circ, I_a = I_{mean} + \frac{a_1}{\sqrt{2}} + \frac{a_3}{\sqrt{2}} = I_{135^\circ} \dots \dots (27)$$

$$pt = 225^\circ, I_a = I_{mean} - \frac{a_1}{\sqrt{2}} - \frac{a_3}{\sqrt{2}} = I_{225^\circ} \dots \dots (28)$$

$$pt = 270^\circ, I_a = I_{mean} - a_1 - a_2 + a_3 = I_{270^\circ} \dots \dots (29)$$

Multiplying (27) by  $\sqrt{2}$

$$\sqrt{2} I_{135^\circ} = \sqrt{2} I_{mean} + a_1 + a_3 \dots \dots (30)$$

Multiplying (28) by  $\sqrt{2}$

$$\sqrt{2} I_{225^\circ} = \sqrt{2} I_{mean} - a_1 - a_3 \dots \dots (31)$$

Subtracting (31) from (30)

$$\sqrt{2} (I_{135^\circ} - I_{225^\circ}) = 2a_1 + 2a_3 \dots \dots (32)$$

Subtracting (29) from (26)

$$I_{90^\circ} - I_{270^\circ} = 2a_1 - 2a_3 \dots \dots (33)$$

Adding (32) and (33)

$$4a_1 = I_{90^\circ} - I_{270^\circ} + \sqrt{2} (I_{135^\circ} - I_{225^\circ}) \dots \dots (34)$$

Subtracting (33) from (32)

$$4a_3 = I_{270^\circ} - I_{90^\circ} + \sqrt{2} (I_{135^\circ} - I_{225^\circ}) \dots \dots (35)$$

## HARMONIC DISTORTION

Hence the percentage of third harmonic distortion is given by

$$100 \frac{a_3}{a_1} = 100 \times \frac{I_{270^\circ} - I_{90^\circ} + \sqrt{2}(I_{135^\circ} - I_{225^\circ})}{I_{90^\circ} - I_{270^\circ} + \sqrt{2}(I_{135^\circ} - I_{225^\circ})} \quad \dots (36)$$

### Method of Determining the Second-harmonic Distortion given by a Cubic Characteristic

Adding (27) and (28)

$$I_{135^\circ} + I_{225^\circ} = 2I_{mean} \quad \dots \dots \dots (37)$$

Adding (26) and (29)

$$I_{90^\circ} + I_{270^\circ} = 2I_{mean} - 2a_2 \quad \dots \dots \dots (38)$$

Subtracting (38) from (37)

$$I_{135^\circ} + I_{225^\circ} - (I_{90^\circ} + I_{270^\circ}) = 2a_2 \quad \dots \dots \dots (39)$$

It has already been shown that

$$4a_1 = I_{90^\circ} - I_{270^\circ} + \sqrt{2}(I_{135^\circ} - I_{225^\circ})$$

Therefore the percentage of second harmonic distortion is given by

$$100 \frac{a_2}{a_1} = 200 \times \frac{I_{135^\circ} + I_{225^\circ} - (I_{90^\circ} + I_{270^\circ})}{I_{90^\circ} - I_{270^\circ} + \sqrt{2}(I_{135^\circ} - I_{225^\circ})} \quad \dots (40)$$

### Total Harmonic Distortion given by a Cubic Characteristic.

It has been shown that with a certain value of anode load it is possible to obtain zero second-harmonic distortion. The third-harmonic distortion increases with increase in the load and the optimum anode load is generally chosen to give minimum percentage of total harmonic distortion.

If second- and third-harmonic distortion only are present the percentage of total harmonic distortion is given by

$$\sqrt{H_2^2 + H_3^2} \dots \dots \dots (41)$$

where  $H_2$  = percentage of second-harmonic distortion.

$H_3$  = percentage of third-harmonic distortion.

### Intermodulation

Most musical sounds consist of a fundamental component together with a number of harmonics. If a single note, with fundamental and harmonic components is applied to an amplifier having a non-linear characteristic, the harmonic content of the note is changed by harmonics introduced in the amplifier. Since these added harmonics have frequencies which are simple multiples of that of the fundamental or one of the harmonics

## HARMONIC DISTORTION

of the original sound, most of them blend harmoniously with the components of the original sound and the output of the amplifier does not sound unpleasant. An exception to this statement is provided by the seventh harmonic which forms a discord with the fundamental. The mere addition of low-order harmonics to a single note, although it alters the shape of the waveform and changes the character of the original sound, cannot of itself cause unpleasant distortion.

If two or more notes are applied simultaneously to a non-linear amplifier, unpleasant sounds may be produced because of the presence in the output of the amplifier of signals with frequencies which do not blend harmoniously with those of the components of the input signal. The introduction of these unwanted signals is due to a non-linear relationship between input and output potentials. This will now be shown mathematically.

Consider a linear  $I_a - V_g$  characteristic, expressed by

$$I_a = a_o + bV_g \quad \dots \quad \dots \quad \dots \quad \dots \quad \dots \quad (42)$$

$$\text{and let } V_g = -V_b + V_{1(\rho k)} \sin p_1 t + V_{2(\rho k)} \sin p_2 t$$

Here  $V_g$  contains three components, a constant negative bias component and two sinusoidal components of frequencies  $p_1/2\pi$  and  $p_2/2\pi$  cycles per second, respectively.

Substituting for  $V_g$  in (42),

$$\begin{aligned} I_a &= a_o + b \left[ -V_b + V_{1(\rho k)} \sin p_1 t + V_{2(\rho k)} \sin p_2 t \right] \\ &= a_o - bV_b + bV_{1(\rho k)} \sin p_1 t + bV_{2(\rho k)} \sin p_2 t \quad \dots \quad \dots \quad (43) \end{aligned}$$

There is no distortion because, as equation (43) shows, the output contains a.c. components having the same frequencies as the input signal. There are no terms with frequencies differing from those of the two input signal components.

Now consider a parabolic  $I_a - V_g$  characteristic, expressed by

$$I_a = a_o + bV_g + cV_g^2 \quad \dots \quad \dots \quad \dots \quad (44)$$

$$\text{and let } V_g = -V_b + V_{1(\rho k)} \sin p_1 t + V_{2(\rho k)} \sin p_2 t \text{ as before.}$$

Substituting for  $V_g$  in (44)

$$\begin{aligned} I_a &= a_o + b \left[ -V_b + V_{1(\rho k)} \sin p_1 t + V_{2(\rho k)} \sin p_2 t \right] \\ &\quad + c \left[ -V_b + V_{1(\rho k)} \sin p_1 t + V_{2(\rho k)} \sin p_2 t \right]^2 \quad \dots \quad (45) \end{aligned}$$

Expanding the right-hand side of (45) and simplifying,

## HARMONIC DISTORTION

$$\begin{aligned}
 I_a = & a_o - bV_b + cV_b^2 + \left[ b - 2cV_b \right] V_{1(p_k)} \sin p_1 t \\
 & + \left[ b - 2cV_b \right] V_{2(p_k)} \sin p_2 t + \frac{cV_{2(p_k)}^2}{2} (1 - \cos 2p_1 t) \\
 & + \frac{cV_{2(p_k)}^2}{2} (1 - \cos 2p_2 t) + cV_{1(p_k)} V_{2(p_k)} \cos(p_1 - p_2)t \\
 & - cV_{1(p_k)} V_{2(p_k)} \cos(p_1 + p_2)t \quad \dots \quad \dots \quad \dots \quad \dots \quad \dots \quad (46)
 \end{aligned}$$

From equation (46) it is apparent that the output contains, in addition to a d.c. component and a.c. components of the wanted frequencies  $p_1/2\pi$  and  $p_2/2\pi$  :—

- (1) A second-harmonic component of frequency  $2p_1/2\pi$ .
- (2) A second-harmonic component of frequency  $2p_2/2\pi$ .
- (3) A component of frequency  $(p_1 - p_2)/2\pi$ , i.e., the difference between the two input signal frequencies.
- (4) A component of frequency  $(p_1 + p_2)/2\pi$ , i.e., the sum of the two input signal frequencies.

The latter two terms, known as the sum and difference components, cause the unpleasant sound from an overloaded amplifier. The process by which they are introduced is known as intermodulation, the two input signals acting as the carrier and modulating signal, to produce sum and difference terms which are equivalent to upper and lower sidebands respectively in amplitude modulation.

As an example, suppose two input signals are applied to an amplifier, the frequencies being 256 c/s and 320 c/s. These frequencies are those of middle C and E and blend harmoniously to give a chord known as a *major third*. Due to non-linearity in the amplifier, the output contains components with frequencies of 64 c/s (the difference term) and 576 c/s (the addition term). The difference frequency is that of C two octaves below the input signal and harmonises with 256 c/s and 320 c/s, but the addition frequency is that of D one octave above the input signal and produces a discord with both 256 c/s and 320 c/s.

### Harmonic Distortion in Push-pull Amplifiers

The load of a push-pull amplifier is coupled to the output valves so that the fundamental-frequency output currents of both valves are additive. If each valve produces an equal amount of second harmonic distortion, and if the phase difference between fundamental and second-harmonic components is the same in both valves the second harmonic components of the separate valves cancel. There is no cancellation, however, in the third harmonic content. In designing push-pull amplifiers, therefore, the load condition is best chosen so that minimum third harmonic distortion is obtained.

## HARMONIC DISTORTION

The description of harmonic distortion and intermodulation distortion has so far been limited to that introduced by non-linearity of valve  $I_a - V_g$  characteristics. There are, however, other sources of distortion in amplifiers, such as grid current, reactive load circuits and apparatus containing iron in the magnetic circuit.

### Harmonic Distortion Due to Grid Current

If an operating condition arises where the grid of a valve becomes positive with respect to the cathode, grid current flows during the positive half-cycles of the input signal. In flowing through the grid-cathode resistance this current sets up a p.d. which tends to make the grid negative and reduces the amplitude of the positive half-cycle. Thus the output signal is greater for negative half-cycles than for positive ones; in other words, second-harmonic distortion is produced. How great this distortion is depends on the magnitude of the resistive component in the grid-cathode circuit and the extent to which the grid is driven positive. If the valve is driven from the secondary winding of an intervalve transformer with a very low resistance the amount of distortion introduced may be kept quite small. Such a system is frequently used in the class-B output stages of public-address amplifiers, but sometimes, as for example, in the modulator stage of a broadcast transmitter, the small amount of harmonic distortion produced by a class-B stage is considered excessive, even when transformers with low-resistance secondary windings are employed. In such circumstances negative feedback is used to reduce the distortion.

### Elliptical Load Lines

If a valve has a load which is appreciably reactive, the load line has the shape of a sheared ellipse, as shown in Fig. 13, and when an input is applied to the valve the operating point moves round the ellipse at the rate of one revolution per cycle of the applied e.m.f. The direction of movement of the operating point is clockwise for an inductive load and anti-clockwise for a capacitive one. The ratio of the major to the minor axis of the ellipse is dependent on the ratio of resistance to reactance (they are assumed to be connected in series) in the load. Thus a predominantly reactive load gives a large ratio. The practical significance of these load lines lies in the fact that for a given value of  $V_g$  there are two possible values of  $I_a$ , one of which applies when  $V_g$  is increasing and the other when it is decreasing. If the ellipse enters the region where the  $I_a - V_a$  characteristics are crowded, the variation of  $I_a$  may not be a true copy of the input signal and harmonic distortion is caused. The shape of the anode-current waveform for a sinusoidal input signal and an inductive load is given in Fig. 13. Under certain conditions, one of which is that the a.c. load is less in value than the d.c. load, the ellipse may cut the  $V_a$  axis.

## HARMONIC DISTORTION

When this occurs, harmonic distortion is inevitable, even if the valve is perfect, i.e., has straight, parallel and equidistant characteristics.

To prevent distortion from this cause it is necessary to present all valves with purely resistive loads, or, if this is impossible, to keep the reactive

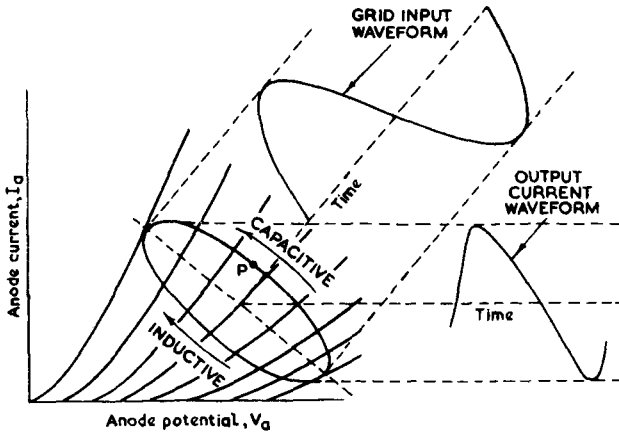

Fig. 13. *Waveform Distortion Produced by an Elliptical Load Line. The Output Load is assumed Inductive*

component as small as possible. In an output transformer, for example, the primary reactance should be very great compared with the reflected value of the load (assumed purely resistive) throughout the frequency range to be amplified; in other words, the net impedance of the two in parallel should be predominantly resistive even at the lowest frequencies. If this point is not observed harmonic distortion occurs, as illustrated in Fig. 13, particularly at low frequencies. Attenuation distortion is also produced as a consequence of the decreasing modulus of the load at low frequencies. At high frequencies harmonic distortion can be produced due to the reactive component of leakage inductance or shunt capacitance, both of which become important at these frequencies. If the external load is not a pure resistance but is, for example, a moving-coil loudspeaker, additional distortion can be produced as a consequence of the complex nature of its impedance.

### Distortion Due to Non-linear Relationship in a Magnetic Circuit

If a transformer in a valve anode circuit has an iron core this constitutes yet another source of harmonic distortion, because the relationship between output and input potentials is dependent on the shape of the  $B-H$  curve for the iron used in the core, and this is never a straight line. The  $B-H$  diagram is such that the curve traced out by increasing values of  $H$  is

## HARMONIC DISTORTION

different from that obtained when  $H$  is decreased. If there is no d.c. in the windings of the transformer, as, for example, when it is parallel-fed, and if the alternating voltage applied to it is sufficient almost to saturate the core magnetically, flattening of both positive and negative peaks occurs, i.e., third-harmonic distortion results.

If d.c. magnetisation is present the flux variations due to an alternating signal occur about an operating point, the position of which depends on the direct current. If the amplitude of flux alternation is great enough, magnetic saturation will be reached on one peak and not on the other i.e., second harmonic distortion is produced. Further increase in the amplitude will result in flattening on both peaks and third-harmonic distortion is added to the second. For a given alternating signal the second-harmonic distortion introduced increases with increase in the d.c. polarisation.



# NEGATIVE FEEDBACK

## General Considerations

The reduction of harmonic distortion to a minimum is one of the chief considerations in amplifier design. Correct choice of component values and valve types is essential, but in recent years it has been established that the use of negative feedback can be an important factor in the reduction of total harmonic content. Negative feedback can also be used to give a required value of output or input impedance, a desired frequency-response curve or to provide a limited range of gain control. The principle of negative feedback is used extensively in the design of BBC amplifiers, and this section is intended to help in the understanding of circuit diagrams given in Technical Instructions.

Basically the principle of feedback consists of taking a voltage from one stage of an amplifier and feeding it back to an earlier stage. If the voltage is fed back in phase opposition to the input signal at the early stage, the gain of the amplifier within the feedback loop is reduced and the feedback is said to be negative. The greater the feedback voltage the more the gain is reduced. Not only is the gain of the amplifier reduced, but so also are spurious voltage components such as harmonics, noise and hum introduced into that part of the amplifier over which feedback is applied. A portion of these spurious voltages is fed to the earlier stage together with the wanted signal, and just as the output voltage is reduced, so is the output of these unwanted noises. The wanted output voltage can be restored by increasing the input signal, but the spurious components produced within the amplifier itself remain at a reduced level.

The gain of an amplifier from input to output terminals may be reduced by the application of negative feedback, but the gains of the individual valves, measured with respect to their grid-cathode signals are, of course, unaffected. Moreover, there are certain parallel-connected feedback circuits which do not affect the gain between input and output terminals and, to appreciate the effect of the feedback, gain must be expressed with respect to the generator voltage of the signal source connected to the input terminals.

Thus, in any consideration of negative-feedback circuits, the term *gain* must be very carefully interpreted and each time the term is used it is advisable to specify the two pairs of circuit points at which the voltage measurements are compared.

## NEGATIVE FEEDBACK

### Effect of Negative Feedback on the Gain of an Amplifier

Fig. 14(a) represents an amplifier of voltage gain  $A$  measured between input and output terminals. If a signal of amplitude  $V_{in}$  is applied to the input, an amplified signal  $V_{out}$  is obtained at the output, where  $V_{out} = AV_{in} = AV_{gk}$

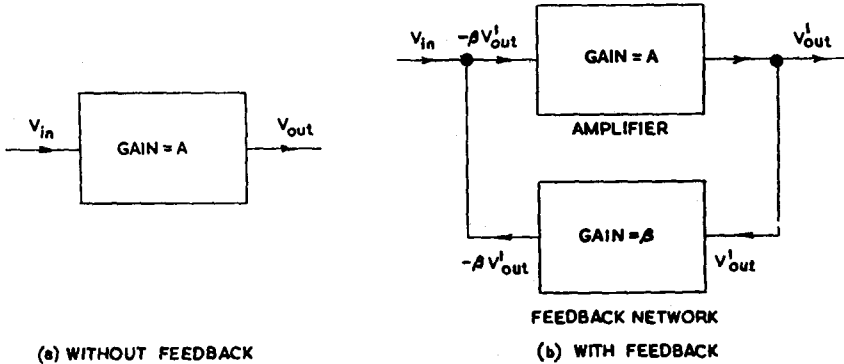

Fig. 14. Effect of Negative Feedback on Gain

Fig. 14(b) shows the conditions in the same amplifier when negative feedback is applied. The feedback voltage is obtained from the output circuit via a network of gain  $\beta$ , which is usually very much smaller than unity. Since the output voltage is  $V'_{out}$ , the feedback voltage  $V_{fb}$  is  $-\beta V'_{out}$ , the negative sign indicating that the feedback voltage is in antiphase to the input voltage. In this and in all feedback circuits discussed the symbol  $V_{fb}$  means the feedback voltage appearing between grid and cathode. In Fig. 14(b) let the feedback voltage be so applied to the input circuit that the grid-cathode voltage

$$V_{gk} = V_{in} - \beta V'_{out}$$

$$\text{But } V'_{out} = AV_{gk} = A(V_{in} - \beta V'_{out}) \quad \dots \quad (47)$$

$$\therefore V'_{out} (1 + A\beta) = AV_{in} \quad \dots \quad (48)$$

$$\therefore \frac{V'_{out}}{V_{in}} = \frac{A}{1 + A\beta} \quad \dots \quad (49)$$

The gain of the amplifier measured between input terminals and output terminals without feedback is  $A$ . With feedback it is  $A/(1 + A\beta)$ . Thus the application of negative feedback reduces the gain to  $1/(1 + A\beta)$  of its original value and the gain  $A'$  with feedback may be expressed

## NEGATIVE FEEDBACK

$$A' = \frac{A}{1 + A\beta} \quad \dots \quad \dots \quad \dots \quad (50)$$

This may be written

$$A' = \frac{1}{\beta + \frac{1}{A}} \quad \dots \quad \dots \quad \dots \quad (51)$$

If  $A$  is so large that  $1/A$  is negligible in comparison with  $\beta$  the gain of the amplifier approximates to  $1/\beta$  and is independent of the gain of the amplifier without feedback. Thus when considerable feedback is used the gain of the amplifier is decided mainly by the constants of the feedback network and is to a large extent independent of the parameters of the valves and also of fluctuations in power supplies.

The symbol  $\beta$  represents the total attenuation in the feedback circuit and is given by  $V_{fb}/V'_{out}$ . In a practical circuit, however, it is frequently necessary to express  $\beta$  as a function of several factors  $\beta_1, \beta_2$ , etc., because the expressions for gain, input impedance and output impedance do not always include the total attenuation in the feedback chain.

### Effect of Negative Feedback on Noise Generated Within the Amplifier

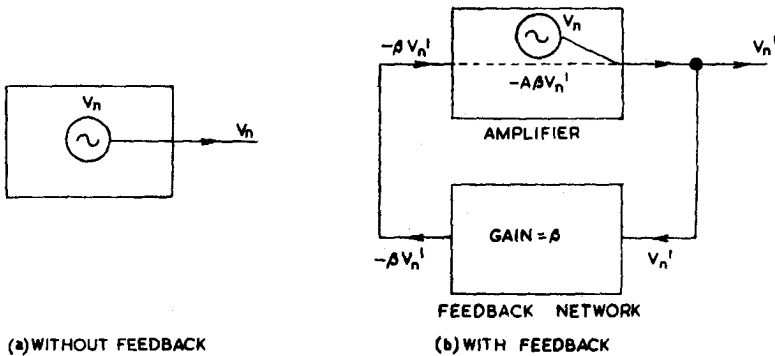

Fig. 15. Effect of Negative Feedback on Noise

Amplifiers give a small output voltage even when there is no input signal. This output is largely composed of valve hiss and hum generated within the amplifier. Fig. 15(a) represents an amplifier with no input signal and the noise voltage  $V_n$  obtained at the output is shown to be due to a generator situated within the amplifier.

Fig. 15(b) shows the conditions in the same amplifier when negative feedback is applied. As before, the noise generator produces an output voltage  $V_n$  but a fraction of the output is now fed back to the input via

## NEGATIVE FEEDBACK

the feedback loop and as a result the noise output voltage becomes  $V_n'$ . From Fig. 15(b) it is clear that

$$V_n' = V_n - A\beta V_n'$$

from which

$$V_n' = \frac{V_n}{1 + A\beta}$$

and

$$\frac{V_n'}{V_n} = \frac{1}{1 + A\beta} \quad \dots \quad \dots \quad \dots \quad \dots \quad (52)$$

In general, noise and hum generated inside the amplifier are reduced by negative feedback to  $1/(1 + A\beta)$  of the original value, the same factor by which gain is reduced.

### Effect of Negative Feedback on Harmonic Distortion Generated Within the Amplifier

It was shown in the section on harmonic distortion that the harmonic-distortion voltage  $V_d$  produced by a valve depends on the grid-cathode signal amplitude, increasing in general with increase in signal amplitude. As the relationship between  $V_d$  and signal amplitude may be complicated, it is convenient to compare the distortion voltage obtained with and without negative feedback for the *same* grid-cathode signal.

Fig. 16(a) shows an amplifier without feedback. For a grid swing  $V_{in}$  the amplifier produces an output  $V_{out}$  together with a certain harmonic-distortion voltage  $V_d$ .

Fig. 16(b) represents conditions in the same amplifier when negative feedback is applied. The feedback decreases the grid-cathode voltage and the output voltage of the amplifier but suppose the input signal is increased to maintain the grid-cathode voltage and the output voltage at their original values. To do this the input signal  $V_{in}$  must be increased to  $V_{in}(1 + A\beta)$  as shown in Fig. 16(b). Let  $V_d'$  be the harmonic-distortion voltage for this increased input signal. Because the input voltage has been increased to give the same output voltage  $V_{out}$  as before,  $V_{out}$  and  $V_{in}$  can be omitted from Fig. 16(b) which then takes the form shown in Fig. 16(c). Although  $V_{in}$  is omitted from Fig. 16(c) it must be remembered that the harmonic distortion voltage  $V_d$  is dependent on  $V_{in}$ . Since the grid-cathode signal is the same in Figs 16(a) and 16(b) the magnitude of  $V_d$  is the same in both and from Fig. 16 (b).

$$V_d' = V_d - A\beta V_d'$$

from which

$$V_d' = \frac{V_d}{1 + A\beta} \quad \dots \quad \dots \quad \dots \quad \dots \quad (53)$$

NEGATIVE FEEDBACK

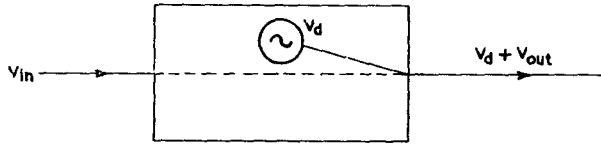

(a) WITHOUT FEEDBACK

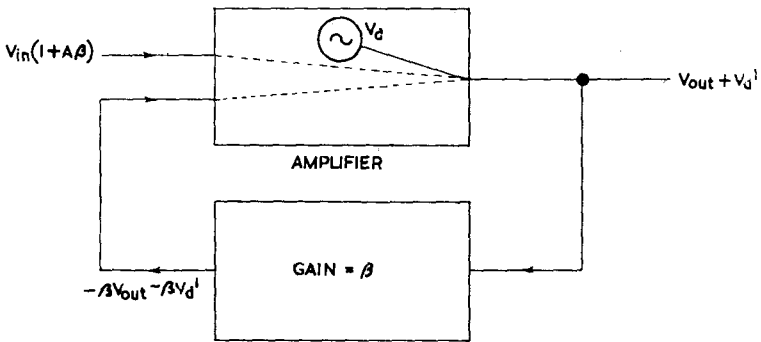

(b) WITH FEEDBACK

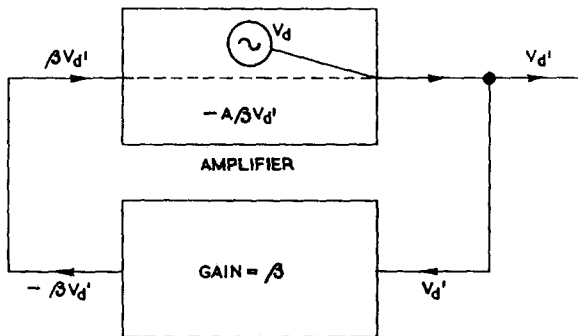

(c) WITH FEEDBACK

Fig. 16. Effect of Negative Feedback on Harmonic Distortion

## NEGATIVE FEEDBACK

Thus the percentage harmonic distortion without feedback is given by

$$H = 100 \frac{V_a}{V_{out}}$$

and with feedback is given by

$$H' = 100 \frac{V_a'}{V_{out}}$$

Since  $V_{out}$  is the same with and without feedback

$$\frac{H'}{H} = \frac{V_a'}{V_a} = \frac{1}{1 + A\beta} \dots \dots \dots (54)$$

Hence the percentage harmonic distortion is reduced by negative feedback to  $1/(1 + A\beta)$  of its original value, the ratio by which gain and noise are reduced.

If the output with feedback is less than without it, the reduction in distortion is likely to be greater than is suggested by expression (54) because of the reduced grid-cathode signal.

### Effect of Negative Feedback on Attenuation Distortion

Suppose an amplifier has a gain  $A_{f_1}$  at a frequency  $f_1$  and a gain  $A_{f_2}$  equal to  $A_{f_1}(1 + k)$  at a frequency  $f_2$  measured with respect to grid-cathode potential. The ratio of  $A_{f_2}$  to  $A_{f_1}$  is  $(1 + k)$  and  $k$  is thus a measure of the attenuation distortion. If  $k = 0$  there is no attenuation distortion.

If the total attenuation in the feedback loop is  $\beta$ , and is independent of frequency, the gain measured from input terminals at  $f_1$  is given by

$$A_{f_1}' = \frac{A_{f_1}}{1 + A_{f_1}\beta} \dots \dots \dots \text{(see equation 50)}$$

and the gain at  $f_2$  becomes

$$A_{f_2}' = \frac{A_{f_2}(1 + k)}{1 + A_{f_1}\beta(1 + k)}$$

The ratio of the gain at  $f_2$  to the gain at  $f_1$  is thus

$$\begin{aligned} \frac{A_{f_2}'}{A_{f_1}'} &= \frac{A_{f_2}(1 + k)}{1 + A_{f_1}\beta(1 + k)} \cdot \frac{1 + A_{f_1}\beta}{A_{f_1}} \\ \therefore \frac{A_{f_2}'}{A_{f_1}'} &= \frac{(1 + k)}{1 + k \frac{A_{f_1}\beta}{1 + A_{f_1}\beta}} \dots \dots \dots (55) \end{aligned}$$

Before the application of negative feedback the gain ratio was  $(1 + k)$ . Thus feedback has reduced the attenuation distortion to

## NEGATIVE FEEDBACK

$$1 / \left( 1 + k \frac{A_{f1}\beta}{1 + A_{f1}\beta} \right) \text{ of its original value.}$$

If  $A_{f1}\beta$  is large compared with unity, expression (55) approaches unity. This signifies that a large degree of feedback tends to make the gains at  $f_1$  and  $f_2$  equal and to eliminate attenuation distortion.

This result only applies to attenuation distortion occurring within the amplifier between the point at which the feedback voltage is derived and the point at which it is re-introduced into the amplifier. Attenuation distortion can also occur as a consequence of variations in the impedance of the external load, and feedback may reduce or exaggerate this, as explained in later sections.

### Types of Negative Feedback

The results deduced, so far, apply to any form of negative-feedback circuit; they all reduce gain, and harmonic and attenuation distortion occurring in that portion of the amplifier over which feedback is applied. But the effect of feedback on the effective anode a.c. resistance of a valve or output impedance of an amplifier and on the consequent attenuation distortion caused by variations in the impedance of the external load, depends on the precise connections used. These take three forms, distinguished by the terms (a) voltage feedback, (b) current feedback, and (c) bridge feedback, which may be regarded as a combination of (a) and (b).

## VOLTAGE FEEDBACK

### General Considerations

A voltage feedback circuit is one which provides a feedback voltage  $V_{fb}$  directly proportional to the output voltage. A basic circuit providing

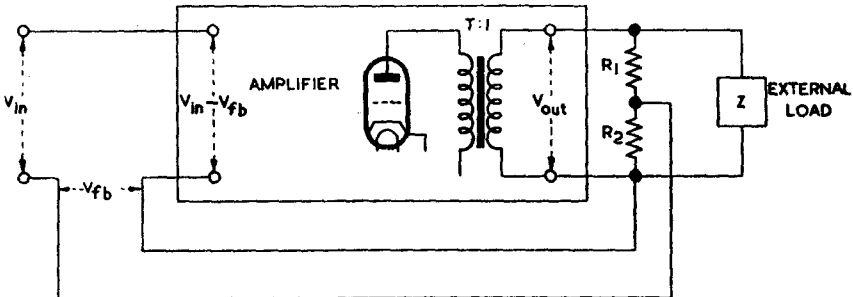

Fig. 17. Basic Connections for Series-connected Voltage Feedback

voltage feedback is shown in Fig. 17.  $Z$  represents the output load and  $R_1 R_2$  a fixed potential divider connected across it, the sum of  $R_1$  and  $R_2$  being great compared with  $Z$  to minimise waste of output power in the

## NEGATIVE FEEDBACK

feedback potentiometer. The voltage  $V_{fb}$  returned to the input of the amplifier is given by

$$V_{fb} = \frac{R_2}{R_1 + R_2} \cdot V_{out} \dots \dots \dots (56)$$

Hence

$$\beta = \frac{R_2}{R_1 + R_2}$$

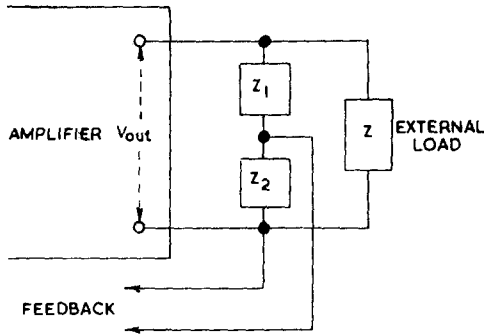

Fig. 18. Reactive Feedback Potentiometer

In this circuit and in most of the circuits discussed,  $\beta$  can be expressed as a resistance ratio. In certain circuits, however, reactances may be present in the feedback circuit and these affect the value of  $\beta$  which then becomes dependent on frequency. To generalise, therefore,  $\beta$  is given by

$$\beta = \frac{Z_2}{Z_1 + Z_2}$$

where  $Z_1$  and  $Z_2$  are the impedances forming the feedback potentiometer as shown in Fig. 18.

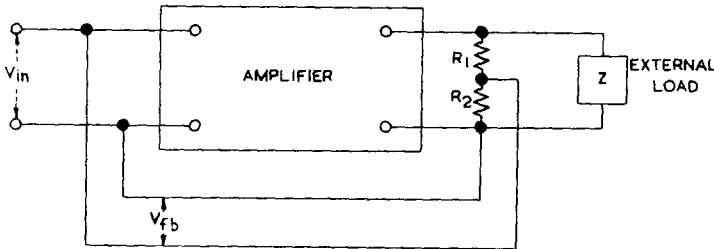

Fig. 19. Basic Connections for Parallel-connected Voltage Feedback

In Fig. 17 the input to the amplifier is composed of  $V_{in}$  and  $V_{fb}$  connected in series. This is an example of *series-connected voltage feedback*. Alternatively  $V_{in}$  and  $V_{fb}$  may be combined as shown in Fig. 19.



## NEGATIVE FEEDBACK

$V_{in}$  and  $V_{fb}$  are connected in parallel across the input terminals of the amplifier. In circuits employing parallel-connected feedback, the value of  $\beta$  and the performance of the amplifier are dependent on the impedance of the source to which the input terminals are connected.

The value of the source impedance can also affect the value of  $\beta$  in circuits employing series-connected feedback but by suitable choice of circuit components it is usually possible to minimise the effect.

### Effect of Voltage Feedback on Gain

The following is a general treatment of the effect of voltage feedback on gain. The result obtained applies to all amplifiers with voltage feedback provided that the correct interpretation is put on  $\beta$  and on gain. This proviso is particularly important in parallel-connected feedback where the value of  $\beta$  is not obvious. Detailed considerations, based on practical circuits, are dealt with later in this section.

Suppose the amplifier (Fig. 17) contains a single valve only, its parameters being  $\mu$ ,  $g_m$  and  $r_a$ . For simplicity, let the ratio of the output transformer be unity. The grid-cathode signal is composed of  $V_{in}$ , the external input signal, and  $V_{fb}$ , the feedback voltage. Provided the sum of  $R_1$  and  $R_2$  is large compared with  $Z$  the output current,  $I$ , is given by

$$I = \frac{\mu V_{gk}}{r_a + Z} = \frac{\mu(V_{in} - V_{fb})}{r_a + Z}$$

The negative sign preceding  $V_{fb}$  indicates that the feedback voltage is negative and in opposition to the external input signal. But  $V_{fb} = \beta V_{out} = \beta IZ$

$$\therefore I = \frac{\mu(V_{in} - \beta IZ)}{r_a + Z} \quad \dots \quad \dots \quad \dots \quad (57)$$

If this equation is solved for  $I$ ,

$$I = \frac{\frac{\mu}{1 + \mu\beta} V_{in}}{\frac{r_a}{1 + \mu\beta} + Z} \quad \dots \quad \dots \quad \dots \quad \dots \quad (58)$$

From this the voltage gain  $V_{out}/V_{in}$  is given by

$$A' = \frac{IZ}{V_{in}} = \frac{\frac{\mu Z}{1 + \mu\beta}}{\frac{r_a}{1 + \mu\beta} + Z}$$

## NEGATIVE FEEDBACK

$$\begin{aligned}
 &= \frac{\mu Z}{r_a + Z + Z\mu\beta} = \frac{\frac{\mu Z}{r_a + Z}}{1 + \frac{\mu Z\beta}{r_a + Z}} \\
 &= \frac{A}{1 + A\beta} \quad \dots \quad \dots \quad \dots \quad \dots \quad (59)
 \end{aligned}$$

This, of course, agrees with equation (50) and shows that the effect of negative feedback is to reduce gain to  $1/(1 + A\beta)$  of its original value.

### Effect of Voltage Feedback on Output Impedance

The anode current of the valve in Fig. 17 may be expressed in terms of  $V_{gk}$ , thus :—

$$I = \frac{\mu V_{gk}}{r_a + Z}$$

or in terms of  $V_{in}$ , thus :—

$$I = \frac{\mu' V_{in}}{r_a' + Z}$$

where  $\mu' = \mu/(1 + \mu\beta)$  and  $r_a' = r_a/(1 + \mu\beta)$ . See expression (58). Thus the relationship between  $V_{in}$  and  $I$  is that which applies to a valve having an amplification factor of  $\mu/(1 + \mu\beta)$  and an anode a.c. resistance of  $r_a/(1 + \mu\beta)$ . The application of feedback may be said to have reduced the amplification factor and anode a.c. resistance to  $1/(1 + \mu\beta)$  of their initial values. If  $\mu\beta \gg 1$ , which frequently applies,  $\mu' \simeq 1/\beta$  and  $r_a' \simeq 1/g_m$ .

If, as in Fig. 17, the anode circuit of a valve is connected by a matching transformer to the output terminals of an amplifier, the output impedance is given by  $r_a'/T^2$  if the transformer has a step-down turns ratio of  $T : 1$ , and  $r_a'$  is the effective anode a.c. resistance of the valve with feedback. Thus any alterations in  $r_a'$  cause corresponding changes in output impedance. It is assumed that the primary resistance is small compared with  $r_a'$  and that the secondary resistance is small compared with the external load. If the winding resistances are not small, they appreciably increase the output impedance and must be taken into account in calculations.

The reduction in the a.c. anode resistance due to voltage feedback is useful when the output valve delivers power to an electro-mechanical device such as a loudspeaker or recording head, for it helps to damp out excessive output at the frequencies where mechanical resonance occurs. An alternative way of expressing this is to say that the application of voltage feedback tends to make the output stage behave as a constant-voltage source. Restating (58) in terms of  $\mu'$  and  $r_a'$

## NEGATIVE FEEDBACK

$$I = \frac{\mu' V_{in}}{r'_a + Z}$$

and the a.c. anode-cathode voltage  $V_a$  is given by

$$V_a = IZ = \frac{\mu' V_{in} Z}{r'_a + Z}$$

If  $r'_a$  is so small compared with  $Z$  that it may be neglected

$$V_a \approx \mu' V_{in} \quad \dots \quad \dots \quad \dots \quad \dots \quad (60)$$

i.e., the a.c. anode-cathode voltage is independent of  $r'_a$  and  $Z$ , and is equal to the product of the amplification factor and the input voltage only.

If voltage feedback is applied over an amplifier consisting of several stages, the anode a.c. resistance of the last valve is reduced to  $r_a/(1 + \mu A \beta)$  where  $\mu$  is the amplification factor of the last valve and  $A$  is the stage gain of the amplifier from the point of injection of the feedback voltage to the grid of the last valve. As  $\mu A \beta$  usually greatly exceeds unity, the new value of the anode a.c. resistance,  $r'_a$  may be written

$$r'_a = \frac{r_a}{\mu A \beta} = \frac{1}{g_m A \beta} \quad \dots \quad \dots \quad \dots \quad (61)$$

The application of feedback over an entire amplifier enables distortion introduced by curvature of valve characteristics and the B-H curves of iron-cored chokes and transformers to be greatly reduced. To obtain low distortion and a very low effective value of output impedance, both desirable for high quality reproduction, feedback must be applied over at least two stages of amplification.

### Instability in Voltage Feedback Amplifiers

When voltage feedback is applied over a number of stages in an amplifier, some inter-valve coupling circuits are included within the feedback loop. These circuits, no matter what their nature, cause phase-shifts at very low and very high frequencies. For example, there is a phase shift at low frequencies in an RC-coupled amplifier because the reactance of the coupling capacitance is comparable with the value of the following grid leak. Decoupling networks and the shunt reactances of chokes and transformer windings also cause phase-shift at low frequencies. Phase-shifts at high frequencies are caused chiefly by leakage inductance in transformers and shunt reactances, particularly those of the output (i.e., anode-cathode) capacitance and the input (i.e., grid-cathode and Miller effect) capacitance in valves. At frequencies within the pass-band, the amplifier ideally produces no phase-shift but the feedback connection causes 180° phase-shift. At a

## NEGATIVE FEEDBACK

frequency outside the pass-band, these sources may produce  $180^\circ$  phase-shift, making  $360^\circ$  shift overall, and if the total gain of the amplifier and feedback circuit is greater than unity at this frequency, oscillation can occur. To avoid this instability at frequencies outside the pass-band, the phase-shift introduced by the amplifier cannot be allowed to exceed  $180^\circ$  at very high and very low frequencies until the product of the gains of the amplifier and feedback circuit (known as the loop gain) has fallen below unity.

There is a direct relationship between the rate of fall of the response outside the pass-band and the phase-shift introduced by the amplifier. Thus 6 db per octave corresponds to a phase-shift of  $90^\circ$  and 12 db per octave to  $180^\circ$ . To avoid instability the response must fall at less than 12 db per octave, at all frequencies where the loop gain is greater than 1. A safe rate of fall is 10 db per octave, corresponding to a phase-shift of  $150^\circ$  (since  $10/6 \times 90^\circ = 150^\circ$ ) and this must be maintained until the loop gain falls to unity. At frequencies well outside the pass-band, where the loop gain is less than unity, the rate of fall of gain and the phase-shift are unimportant because there is insufficient feedback to maintain oscillation.

It is often difficult to avoid instability when large amounts of feedback are employed; for example suppose an amplifier is required to have a pass-band of 30 c/s to 15,000 c/s and 40 db of feedback. Within the pass-band the loop gain is 40 db and this must fall at 10 db per octave or less to 0 db. This necessitates controlling the shape of the frequency response curve for 4 octaves above and below the pass-band limits, i.e., from 2 c/s to 240 kc/s, a very wide range.

More information on this subject can be obtained from an article by Bode.\*

### Effective Characteristics of a Valve with Voltage Feedback

The reduction in amplification factor and anode a.c. resistance due to negative feedback has been shown analytically; it will now be illustrated graphically by the use of  $I_a - V_a$  characteristics plotted with respect to  $V_{in}$ . These can be determined experimentally with a circuit such as Fig. 20. The fixed potential divider  $R_1 R_2$  is connected between the anode and cathode, and the grid is returned to the junction of  $R_1$  and  $R_2$  to provide feedback of the fraction  $R_2/(R_1 + R_2)$  of the anode potential. The values of  $R_1$  and  $R_2$  are chosen to give the desired value of  $\beta$ . The screen is maintained at a suitable positive potential and  $V_a$  is varied, the corresponding values of  $I_a$  being noted on the milliammeter. This can be done for various values of  $V_{in}$  and a family of curves obtained. It should be noted that

---

\* H. W. Bode, "Relations between Attenuation and Phase in Feedback Amplifier Design," *Bell Technical Journal*, July, 1940, Vol. 19, p. 421.

## NEGATIVE FEEDBACK

$V_{in}$  represents a steady potential equivalent to grid bias. The shape of the characteristics determined in this way can also be deduced from the  $I_a - V_a$  characteristics as follows :

The solid curves in Fig. 21 are the  $I_a - V_a$  characteristics of a pentode valve in terms of  $V_{gk}$ . Suppose feedback is applied, as indicated in Fig. 20, the value of  $\beta$  being 0.1 ( $R_1 = 9R_2$ ). Consider the point A in Fig. 21, where  $V_{gk} = 0$  and  $V_a = 100$ . Due to feedback, a potential of 10 volts appears across  $R_2$ , tending to make the grid positive. To make the grid-cathode potential zero,  $V_{in}$  (Fig. 20) must be  $-10$  volts. A is thus one point on the  $I_a - V_a$  characteristics for  $V_{in} = -10$  volts.

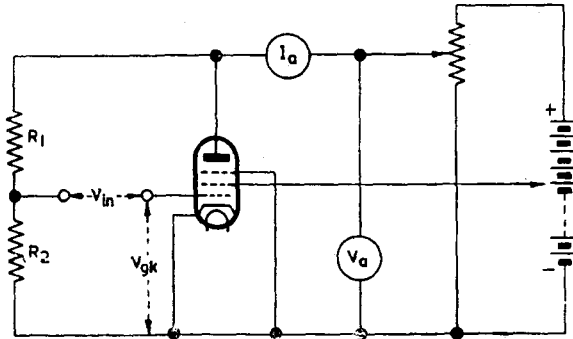

Fig 20. Circuit for determining the Effective  $I_a - V_a$  Curves of a Valve with Voltage Feedback

In general  $V_{in} = -\beta V_a + V_{gk}$ . Where  $V_{gk} = +10$ , and  $V_a = 200$  volts,  $\beta V_a = 20$  volts and hence  $V_{in} = -10$  volts. By repeating this process, the dotted characteristics of Fig. 21 are obtained and they are the characteristics which are effective when feedback is applied.

The dotted characteristics have a greater slope than the solid curves; this shows that the effective  $r_a$  is decreased by the application of voltage feedback. For a given change in grid potential the dotted curves have a closer horizontal spacing than the original characteristics; this indicates that the stage gain is reduced by feedback. The intercepts made on the load line CD by the dotted curves are more uniform than those made by the solid curves, showing that a decrease in harmonic distortion occurs due to feedback. Fig. 20 does not indicate a very great degree of negative feedback; it is sufficient to reduce the stage gain about 2.5 times. If sufficient feedback is used to reduce the gain by about 30 times the effective characteristics become practically straight, parallel and equidistant.

The load line CD represents a load resistance equally suitable for the dotted or the solid characteristics and it emphasises the fact that the optimum load of a valve is unaffected by applying voltage feedback even though the

## NEGATIVE FEEDBACK

effective value of  $r_a$  is reduced. The lower end D of the load line in Fig. 21 cannot be placed below the  $V_a$  axis and the upper end C cannot cross the characteristic for  $V_{gk} = 0$  because if the grid is allowed to go positive with respect to the cathode, the resulting grid current causes harmonic distortion. To avoid distortion the load line must lie wholly between the boundaries defined by  $I_a = 0$  and  $V_{gk} = 0$  and these boundaries are not affected by

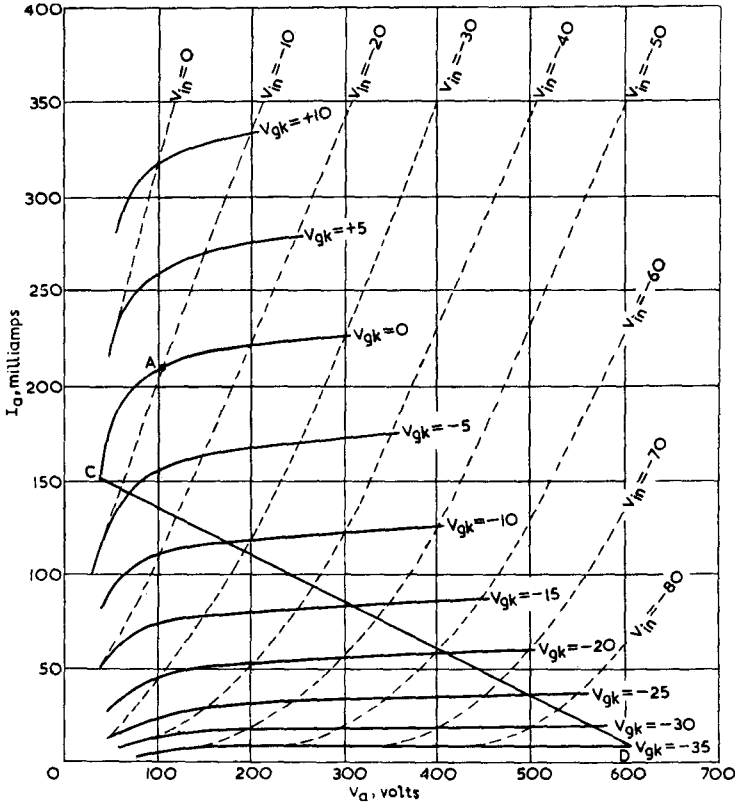

Fig. 21. Effective  $I_a - V_a$  Curves (dotted lines) of a Pentode Valve with Voltage Feedback

negative feedback. Thus the optimum load of an amplifier can be calculated from the characteristics in terms of  $V_{gk}$  of the output stage and is independent of the amount of feedback used.

The dotted characteristics in Fig. 21 are somewhat similar in shape to the  $I_a - V_a$  curves of a triode valve, but comparisons between them and the characteristics of a real triode of equal amplification factor and  $r_a$  show that

## NEGATIVE FEEDBACK

the pentode with feedback has a superior performance. This is particularly marked with respect to anode efficiency, i.e., the ratio of maximum a.c. power output to the power drawn from the h.t. source for a given percentage distortion. For a triode valve under class-A conditions this rarely exceeds 25 per cent., but for a pentode with feedback the efficiency may be 45 per cent. This is because the load line intersects the characteristic for  $V_{gk} = 0$  at a lower value of  $V_a$  for a pentode than for a triode.

### Particular Applications of Voltage Feedback

#### Gain Control

Since the voltage gain of an amplifier depends on the attenuation in the feedback circuit, it is clear that the gain can be controlled by altering the value of  $\beta$ . One way in which this can be done is illustrated in Fig. 22.

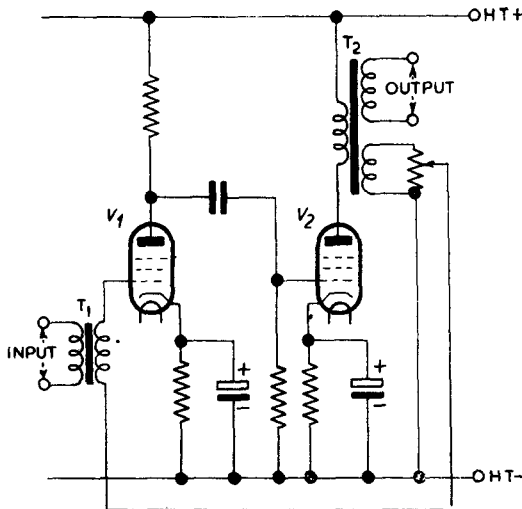

Fig. 22. Gain Control by Voltage Feedback

The secondary winding of  $T_1$  is returned to the slider of a potentiometer connected across a tertiary winding on the output transformer winding. Since the amount of feedback which can be used in an amplifier must be limited if instability is to be avoided, 30 db is about the maximum variation in gain which can be achieved. If a greater variation is required, the feedback control may be ganged with a normal potential divider in the main amplifying chain.

#### Tone Control

By use of reactances in the feedback chain the frequency response of an amplifier can be modified as desired. If a very large degree of feedback is

## NEGATIVE FEEDBACK

used, the frequency response of the amplifier is mainly determined by the constants of the feedback loop ; these constants are sometimes selected to compensate the attenuation distortion occurring in other stages of the amplifier outside the feedback loop.

In Fig. 23, for example, a rising high-frequency response is obtained by including the capacitor  $C_1$ . The value of  $C_1$  is chosen so that its reactance at high frequencies is small compared with  $R_1$ , making the impedance of the

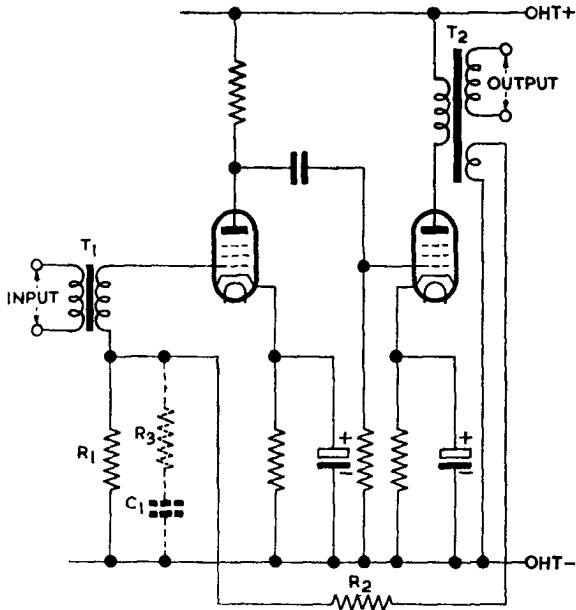

Fig. 23. Tone Control by Voltage Feedback

network  $R_1 C_1$  fall as frequency rises. Thus, the effective value of  $\beta$  falls and the gain of the amplifier rises with increase in frequency. The total *top-lift* obtained in this circuit is limited by the gain of the amplifier without feedback ; if 25 db of feedback is used, the *top-lift* given by Fig. 23 cannot exceed 25 db. The *top-lift* can, however, be limited to less than the amount of feedback by placing a resistor ( $R_3$ ) in series with  $C_1$ . If  $R_3$  is made equal to, say,  $R_1/10$ , the maximum rise in high-frequency response will be limited to 20 db provided, of course, that more than 20 db of feedback is used.

### Series-connected Voltage Feedback. More Detailed Considerations

#### 1. Effect on Gain

In Fig. 24 a feedback voltage is obtained from the secondary winding of the output transformer and returned to the cathode circuit. The resistors



## NEGATIVE FEEDBACK

$R_k$  and  $R_{fb}$  form a potential divider across the secondary winding and the voltage developed across  $R_k$  is  $\beta_1 V_{out}$ ,

$$\text{where } \beta_1 = \frac{R_k}{R_k + R_{fb}}$$

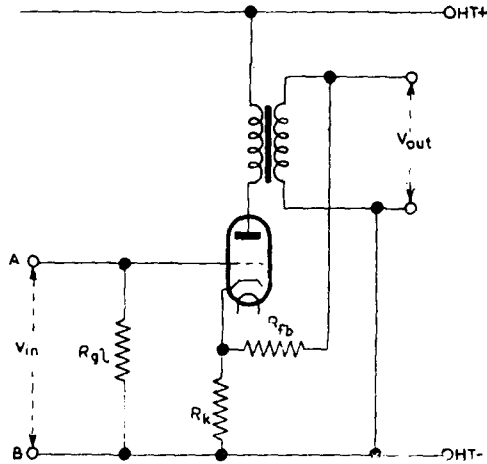

*Fig. 24. A Simple Example of Series-connected Voltage Negative Feedback in which the Cathode Resistor  $R_k$  functions simultaneously as a Feedback and as a Cathode-biasing Component*

The grid leak  $R_{gl}$  is so connected that any voltage developed across  $R_k$  is effectively applied between grid and cathode. Hence the feedback voltage  $V_{fb}$  is equal to  $\beta_1 V_{out}$  and the total attenuation in the feedback circuit is given by

$$\frac{V_{fb}}{V_{out}} = \beta_1 = \frac{R_k}{R_k + R_{fb}}$$

If the resistance of the secondary winding is small compared with  $R_{fb}$  the two resistors  $R_k$  and  $R_{fb}$  function in parallel to form a cathode-biasing resistance of value  $R_k R_{fb} / (R_k + R_{fb})$ . The large by-pass capacitor normally associated with cathode-bias circuits cannot be used in this instance because it would reduce the voltage feedback to a negligible value. The omission of a by-pass capacitor results in a voltage developed across  $R_k$  and  $R_{fb}$  in parallel by the a.c. component of the anode current. Thus there is current feedback, in addition to the voltage feedback.

Altogether there are three voltage components across  $R_k$  :

- (i) A steady bias component,
- (ii) An alternating component due to voltage feedback from the output transformer secondary,

## NEGATIVE FEEDBACK

(iii) An alternating component due to current feedback.

The effects of the current feedback are generally small compared with those of the voltage feedback and will therefore be neglected in this section. It will be assumed that the value of  $R_k$  and  $R_{fb}$  are chosen to give the desired voltage feedback and the correct cathode bias.

$$\begin{aligned} \text{In Fig. 24 } V_{gk} &= V_{in} - V_{fb} \\ &= V_{in} - \beta_1 V_{out} \end{aligned}$$

$$\text{But } V_{out} = A V_{gk}$$

where  $A$  is the gain of the amplifier to the secondary winding, with respect to a grid-cathode signal.

$$\therefore V_{out} = A(V_{in} - \beta_1 V_{out})$$

$$\therefore \frac{V_{out}}{V_{in}} = A' = \frac{A}{1 + A\beta_1} \quad \dots \quad \dots \quad \dots \quad (62)$$

where  $A'$  is the gain between output and input terminals

Fig. 25 illustrates a modification of Fig. 24, in which separate resistors in the cathode circuit provide feedback and grid bias. The lower end of the grid leak  $R_{gl}$  is returned to the junction of  $R_b$  and  $R_k$ . The steady p.d. developed across  $R_b$  by the d.c. component of the anode current provides grid bias and the large capacitance  $C_b$  prevents current feedback due to  $R_b$ . Voltage feedback is provided by  $R_k$  and  $R_{fb}$ .  $R_k$  clearly cannot be bypassed by a large capacitor and thus provides some current feedback in addition to voltage feedback. This current feedback is negligible if  $R_k$  is small compared with the reciprocal of the working mutual conductance\* and as there is usually little difficulty in meeting this requirement, the effects of current feedback are neglected in this section.

The changed grid-leak connection modifies the feedback fraction because the feedback voltage,  $V_{fb}$ , between grid and cathode is less than  $\beta_1 V_{out}$  developed across  $R_k$  and is given by

$$V_{fb} = \beta_1 \beta_2 V_{out} \quad \dots \quad \dots \quad \dots \quad (63)$$

$$\text{where } \beta_1 = \frac{R_k}{R_k + R_{fb}}$$

$$\text{and } \beta_2 \dagger = \frac{R_{gl}}{R_{gl} + R_{gen}}$$

\* See page 81

† It is assumed that  $R_{gen}$  and  $R_{gl}$  are together so large that their shunting effect on  $R_k$  is negligible.

## NEGATIVE FEEDBACK

$R_{gen}$  is the resistance of the signal source connected across the input terminals. Thus the total attenuation in the feedback circuit is given by

$$\frac{V_{fb}}{V_{out}} = \beta = \beta_1 \beta_2$$

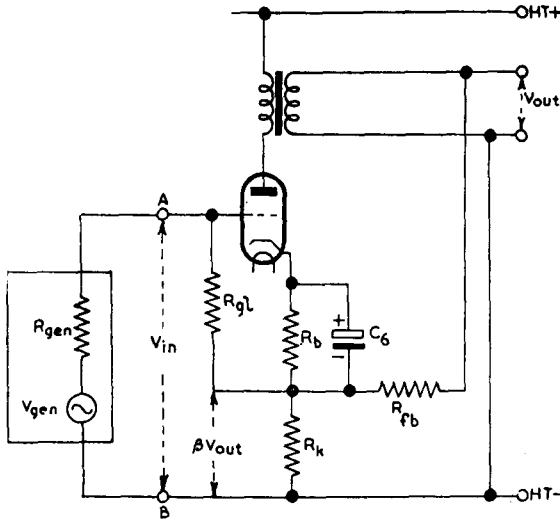

**Fig. 25. A More Complex Example of Series-connected Voltage Negative Feedback in which Separate Cathode Resistors are used for Grid Bias and Feedback.  $R_b$  is the Bias Resistor and  $R_k$  the Feedback Resistor**

In many circuits the valve is fed from the anode of the previous valve via an RC-coupling circuit and  $R_{gen}$  is given by the value of the anode resistor  $R_l$  and the a.c. anode resistance  $r_a$  of the previous valve in parallel. If  $r_a$  greatly exceeds  $R_l$  as, for example, when the previous valve is a pentode,  $R_{gen}$  may be taken as approximately equal to  $R_l$ . In such a circuit  $R_{gen}$  is usually small compared with  $R_{gl}$  and  $\beta_2$  is very nearly equal to 1. In this instance  $\beta$  may be taken as equal to  $\beta_1$  with very little error and the gain of the circuit of Fig. 25 may be calculated from the formula applicable to Fig. 24.

If  $R_{gen}$  is not small compared with  $R_{gl}$ ,  $\beta$  will depend on the value of  $R_{gen}$  and the linearity of the amplifier and its output impedance will depend on the source impedance as well as  $R_k$  and  $R_{fb}$ .

As shown in Appendix I, the gain of the amplifier, measured between *input terminals* and *output terminals* is

## NEGATIVE FEEDBACK

$$A' = \frac{V_{out}}{V_{in}} = \frac{A}{1 + A\beta_1}$$

where  $A$  is the gain from grid and cathode to transformer secondary.

This ratio is, of course, independent of the source impedance and in order to calculate the reduction in gain due to feedback in circuits similar to Fig. 25, the gain should be expressed by the ratio

$$\frac{\text{output voltage}}{\text{generator voltage of signal source}} = \frac{V_{out}}{V_{gen}}$$

In the circuit of Fig. 25,

$$\frac{V_{out}}{V_{gen}} = \frac{A\beta_2}{1 + A\beta_1\beta_2} \dots \dots \dots (64)$$

where  $A$ ,  $\beta_1$  and  $\beta_2$  are as defined above. This result is proved in Appendix I.

Equation (64) can be deduced from Fig. 25 and equation (50). The circuit comprises an amplifying stage of gain  $A$  preceded by a fixed potential divider of attenuation  $\beta_2$ , making the overall gain  $A\beta_2$  in the absence of feedback. Substituting  $A\beta_2$  for  $A$  and  $\beta_1$ , for  $\beta$  in equation (50) gives equation (64).

### 2. Effect on Input Impedance

The input impedance of the amplifier in Fig. 24 is composed of  $R_{gl}$  and the valve input impedance in parallel. At audio frequencies the valve input impedance is usually very much greater than  $R_{gl}$  and the amplifier input impedance may be taken as  $R_{gl}$  with little error. The application of negative feedback to the valve does not appreciably effect the amplifier input impedance unless it reduces the valve input impedance to the order of  $R_{gl}$ . As this is unlikely in practice it may be said that the amplifier input impedance for this circuit is unaffected by feedback.

In Fig. 25  $R_{gl}$  is connected to a tapping point on the cathode resistor and the voltage across  $R_{gl}$  is made up of  $V_{in}$  and feedback voltage  $\beta_1 V_{out}$  connected in series. Thus the current in  $R_{gl}$  depends on the feedback voltage and the amplifier input impedance depends on the feedback constants.

If  $R_k$  is made zero, the voltage feedback disappears and  $R_{gl}$  is connected directly across the input terminals. Clearly the input impedance of the amplifier is  $R_{gl}$  in the absence of feedback.

When feedback is present the grid-cathode signal of  $V_1$  is given by

$$V_{gk} = V_{in} - \beta_1 V_{out}$$

and

$$\beta_1 V_{out} = A\beta_1 V_{gk}$$

where  $A$  is the gain of the amplifier from grid and cathode to the secondary

## NEGATIVE FEEDBACK

of the output transformer.

$$\begin{aligned} \therefore V_{gk} &= V_{in} - A\beta_1 V_{gk} \\ \therefore V_{gk} &= \frac{V_{in}}{1 + A\beta_1} \quad \dots \quad \dots \quad \dots \quad (65) \end{aligned}$$

Now input impedance =  $\frac{\text{input voltage}}{\text{input current}}$

$$\begin{aligned} \therefore R_{in} &= \frac{V_{in}}{\frac{V_{gk}}{R_{gk}}} \\ &= \frac{V_{in}}{\frac{V_{in}}{R_{gk}(1 + A\beta_1)}} \\ \therefore R_{in} &= (1 + A\beta_1)R_{gk} \quad \dots \quad \dots \quad \dots \quad (66) \end{aligned}$$

Thus the application of series-connected voltage feedback increases the input impedance of the amplifier by  $(1 + A\beta_1)$  times where  $\beta_1 = R_k/(R_k + R_{fb})$ . Although  $R_{gen}$  and  $R_{gk}$  decide the value of  $\beta_2$  and hence the feedback fraction,  $\beta_2$  does not enter into the expression for input impedance.

### 3. Effect on Output Impedance

In an amplifier in which there is no feedback from the output to an earlier part of the circuit, the output impedance is decided by the characteristics of the output stage and the input circuit has no influence on it.

When feedback is applied, a connection is provided between input and output circuits and conditions in one can influence those in the other. The amplifier now begins to acquire some of the characteristics of a network, in that the output impedance is partially dependent on the source resistance.

It is shown in Appendix 1 that the effective anode a.c. resistance  $r_a'$  of the valve in Fig. 25 is given by

$$r_a' = \frac{r_a}{1 + \mu\beta_1\beta_2\beta_3} \quad \dots \quad \dots \quad \dots \quad (67)$$

where  $\beta_1$  and  $\beta_2$  are as defined above

$$\beta_3 = 1/T$$

$T:1$  = step-down ratio of the output transformer.

Thus  $r_a'$  depends on  $R_{gen}$  the internal resistance of the signal source, particularly if  $R_{gen}$  is large compared with  $R_{gk}$ . If  $R_{gen}$  is small compared with  $R_{gk}$ ,  $\beta_2$  tends to unity and  $r_a'$  to  $r_a/(1 + \mu\beta_1\beta_3)$ .

The output impedance of the amplifier (Fig. 25) is given by  $r_a'/T^2$ .

## NEGATIVE FEEDBACK

### Parallel-connected Voltage Feedback. More Detailed Considerations

#### 1. Effect on Gain

Fig. 26 shows the circuit of a single-stage amplifier in which voltage feedback is provided by the fixed potential divider  $R_{fb1} R_{fb2}$  but the method of injecting the voltage across  $R_{fb2}$  into the valve input circuit differs from that in Figs. 24 and 25. The cathode of the valve is virtually earthed at audio frequencies by the large capacitance  $C_b$  in parallel with  $R_b$  and the feedback voltage is applied to the grid circuit by way of the grid leak  $R_{gl}$  and appears across  $AB$ . The signal input to the amplifier also appears across  $AB$  and the feedback system is an example of parallel-connected voltage negative feedback. An example of this in BBC apparatus is provided by the circuit of  $V1$  in the  $GPA/1$  amplifier.

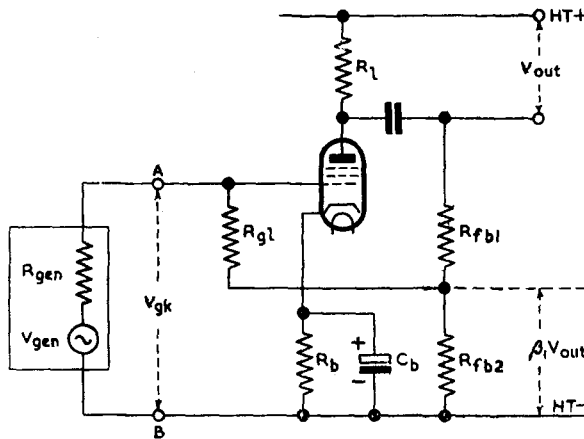

Fig. 26. An Example of Parallel-connected Voltage Feedback

$R_{gl}$  and  $R_{gen}$  are connected in series across  $R_{fb2}$  and form a second potential divider in the feedback loop since only the voltage appearing across  $R_{gen}$  is applied between grid and cathode. Thus the value of  $\beta$  and hence the performance of the amplifier is dependent on the value of the source resistance.

It is shown in Appendix 2 that in the circuit of Fig. 26

$$V_{fb} = \beta V_{out} = \beta_1(1 - \beta_2)V_{out}$$

where

$$\beta_1 = \frac{R_{fb2}}{R_{fb1} + R_{fb2}} \quad \text{and} \quad \beta_2 = \frac{R_{gl}}{R_{gen} + R_{gl}}$$

from which it can be deduced that there is no feedback if  $R_{gen} = 0$  or if  $R_{gl}$  approaches infinity.

Since the input terminals of the amplifier are virtually connected directly to the grid and cathode of the valve, the gain of the amplifier between

## NEGATIVE FEEDBACK

*input terminals* and *output terminals* (i.e.,  $V_{out}/V_{in}$ ) is given by  $A \simeq g_m R_l$  whether feedback is applied or not. Measured in this way the voltage gain is thus independent of the source resistance and in order to calculate the reduction in gain brought about by the negative feedback the gain should be measured, as for Fig. 25, by the expression

$$\text{gain} = \frac{\text{output voltage}}{\text{generator voltage of signal source}} = \frac{V_{out}}{V_{gen}}$$

From Appendix 2

$$\frac{V_{out}}{V_{gen}} = \frac{A \beta_2}{1 + A \beta_1 (1 - \beta_2)} \quad \dots \quad \dots \quad \dots \quad \dots \quad (68)$$

where  $A = \frac{V_{out}}{V_{in}} = \frac{V_{out}}{V_{gk}}$  = gain between input and output terminals of the amplifier. Thus the gain is dependent upon the values of the feedback components  $R_{fb1}$  and  $R_{fb2}$  and on the ratio of the grid leak to the generator resistance of the signal source.

### 2. Effect on Input Impedance

If  $R_{fb2}$  is made zero in Fig. 26 there is no feedback and the input resistance of the amplifier is clearly  $R_{gl}$  since this component is connected directly across the input terminals. The cathode of the valve is effectively earthed at audio frequencies and the input terminals are virtually connected directly to grid and cathode. Thus  $V_{in} = V_{gk}$  and for an input signal  $V_{gk}$  the current in  $R_{gl}$  is  $V_{in}/R_{gl}$ .

Suppose the input signal is  $V_{in}$  when feedback is applied. The p.d. across  $R_{gl}$  is made up of  $V_{gk}$  volts at the end connected to the grid and  $\beta_1 V_{out}$  volts at the other end and as these two voltages are additive the total e.m.f. across  $R_{gl}$  is  $V_{gk} + \beta_1 V_{out}$ .

$$\text{Now} \quad \beta_1 V_{out} = \beta_1 A V_{in}$$

$$\text{and} \quad V_{gk} = V_{in}$$

$$\therefore \text{ p.d. across } R_{gl} = V_{in} (1 + A \beta_1)$$

$$\therefore \text{ current in } R_{gl} = \frac{V_{in} (1 + A \beta_1)}{R_{gl}}$$

But the input signal to the amplifier is  $V_{in}$

$$\therefore \text{ input impedance} = \frac{\text{input voltage}}{\text{input current}}$$

## NEGATIVE FEEDBACK

$$= \frac{V_{in}}{\frac{V_{in}(1 + A\beta_1)}{R_{gl}}}$$

$$\therefore R_{in} = \frac{R_{gl}}{1 + A\beta_1} \quad \dots \quad \dots \quad \dots \quad (69)$$

Thus the input resistance has been reduced to  $1/(1 + A\beta_1)$  of its original value by the application of negative feedback.

### 3. Effect on Output Impedance

From Appendix 2

$$r_a' = \frac{r_a}{1 + \mu\beta_1(1 - \beta_2)} \quad \dots \quad \dots \quad (70)$$

Thus  $r_a'$  depends on  $\beta_2$  and hence on  $R_{gen}$ , particularly when  $\beta_2$  approaches unity and  $R_{gen}$  is small compared with  $R_{gl}$  (compare this result with that for series-connected feedback). If  $R_{gen}$  is large compared with  $R_{gl}$ ,  $\beta_2$  tends to zero and  $r_a'$  to  $r_a/(1 + \mu\beta_1)$ .

If  $R_l$  in Fig. 26 represents a direct-coupled external load, the output impedance of the amplifier is simply  $r_a'$  but if a transformer of turns ratio  $T : 1$  is included between valve and load, the output impedance becomes  $r_a'/T^2$ .

In certain BBC amplifiers  $R_l$  is a resistor within the amplifier and the external load is connected directly in parallel with it. For such a circuit the output impedance is that of  $r_a'$  and  $R_l$  in parallel, i.e.,  $r_a' R_l / (r_a' + R_l)$ . If a transformer of turns ratio  $T : 1$  is included between  $R_l$  and the external load, the output impedance is given by

$$\frac{1}{T^2} \cdot \frac{r_a' R_l}{r_a' + R_l}$$

In these circumstances, the value of  $T$  is chosen to match the external load to the parallel impedance formed by the optimum load of the valve and  $R_l$ .

### Some Practical Voltage Feedback Circuits and Worked Examples

1. The most obvious and simple way of applying voltage feedback is that shown in Fig. 27. This illustrates an amplifier consisting of a single pentode valve with input and output transformers. A fixed potential divider  $R_1 R_2$  is connected between anode and h.t. negative, the p.d. across  $R_2$  being used as feedback voltage. This is an example of series-connected feedback. The values of  $R_1$  and  $R_2$  must satisfy the following conditions:—

- (1) They must provide the feedback wanted according to the expression  $\beta = R_2/(R_1 + R_2)$ .



## NEGATIVE FEEDBACK

- (2) The value of  $R_1 + R_2$  must be large compared with the optimum load of the valve.

Let  $r_a = 50,000$  ohms  
 $\mu = 500$   
 $g_m = 10$  mA/volt  
 optimum load = 5,000 ohms  
 external load = 600 ohms

It is required to find :

- (a) turns ratio of the output transformer for maximum power output,
- (b) voltage gain from grid-cathode to output transformer secondary.
- (c) output impedance without feedback,
- (d) value of  $\beta$  to give an output impedance of 600 ohms,
- (e) value of  $R_1$ ,  $R_2$  and  $C$  to satisfy (d),
- (f) gain from input-transformer secondary to output transformer secondary with feedback,

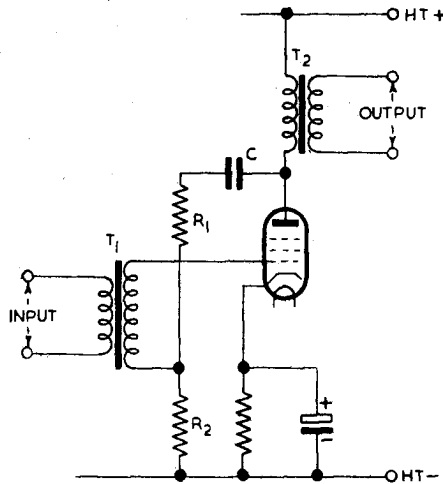

Fig. 27. The Potential-divider Method of Applying Voltage Feedback to a Single-valve Amplifier

- (a) The turns ratio for maximum power output is given by the usual expression

$$\begin{aligned}
 T &= \sqrt{\frac{\text{optimum load}}{\text{external load}}} \\
 &= \sqrt{\frac{5000}{600}} \\
 &= 2.89 : 1
 \end{aligned}$$

## NEGATIVE FEEDBACK

(b) The voltage gain of the amplifier from grid-cathode to anode is given by

$$\begin{aligned} A &\simeq g_m R_i \\ &= \frac{10}{1000} \times 5000 \\ &= 50 \text{ times.} \end{aligned}$$

But the output transformer has a step-down turns ratio of 2.89 : 1. Hence the voltage gain from grid-cathode to output transformer secondary is given by

$$\begin{aligned} 50 \times \frac{1}{2.89} \\ \simeq 17 \end{aligned}$$

(c) The output impedance without feedback is given by  $r_a/T^2$  where  $T^2 = 5,000/600$ . Thus the output impedance is given by

$$\begin{aligned} \frac{50,000 \times 600}{5,000} \\ = 6,000 \text{ ohms.} \end{aligned}$$

(d) If the output impedance is to be 600 ohms,  $r_a'$  must be  $T^2 \times 600$  ohms. Since  $T^2 = 5,000/600$ ,  $r_a'$  is given by

$$\frac{5,000 \times 600}{600} = 5,000 \text{ ohms}$$

It was shown on p. 33 that

$$r_a' = \frac{r_a}{1 + \mu\beta}$$

This may be written in the form

$$\beta = \frac{r_a - r_a'}{\mu r_a'}$$

Putting  $r_a = 50,000$  ohms,  $r_a' = 5,000$  ohms and  $\mu = 500$

$$\begin{aligned} \beta &= \frac{50,000 - 5,000}{500 \times 5,000} \\ &= \frac{9}{500} \end{aligned}$$

## NEGATIVE FEEDBACK

- (e) In Fig. 27  $\beta$  is given by  $R_2/(R_1 + R_2)$ , provided that the reactance of  $C$  is negligible compared with  $(R_1 + R_2)$ . Since  $\beta = 9/500$

$$\frac{R_2}{R_1 + R_2} = \frac{9}{500}$$

There is an infinite series of values for  $R_1$  and  $R_2$  that satisfies this equation and the only additional circuit requirement is that the sum of  $R_1$  and  $R_2$  should be large compared with the optimum load of the valve. Suitable values are  $R_1 = 500,000$  ohms and  $R_2 = 9,000$  ohms, giving a value of  $\beta$  within 2 per cent. of that required. The reactance of  $C$  must be small compared with 500,000 ohms at the lowest frequency the amplifier is required to pass. For an audio-frequency amplifier in which  $R_1 = 500,000$  ohms  $C$  can be  $0.1 \mu F$

- (f) Expression (50) gives the gain of the amplifier from input-transformer secondary to anode with feedback,  $A'$ , as

$$\begin{aligned} A' &= \frac{A}{1 + A\beta} \\ &= \frac{50}{1 + 50 \times \frac{9}{500}} \\ &= \frac{50}{1.9} \\ &\approx 26 \end{aligned}$$

The gain, with feedback, from input-transformer secondary to output-transformer secondary is thus  $\frac{26}{2.89} \approx 9$ .

2. Fig. 28 shows another method of applying voltage feedback used in amplifiers *TV/17*, *TV/18*, *TV/19*, *D/9 (V2)*, *D/10*, *A/11 (V2)*, *C/4* and *GPA/1 (V2)*. The feedback voltage is obtained from a tertiary winding on the output transformer and is injected into the cathode circuit of the valve. Let the valve have the following constants:—

$$r_a = 1,000,000 \text{ ohms}$$

$$\mu = 5,000$$

$$g_m = 5 \text{ mA/volt}$$

$$\text{optimum load} = 40,000 \text{ ohms}$$

The external load of the amplifier is required to be 300 ohms and the gain from input-transformer secondary to output-transformer secondary to be 10.

It is required to determine:

- (a) the turns ratio of the output transformer with respect to the secondary winding,

## NEGATIVE FEEDBACK

- (b) the turns ratio of the output transformer with respect to the tertiary winding,  
 (c) the output impedance of the amplifier.
- (a) The turns ratio of the output transformer is given by the usual expression

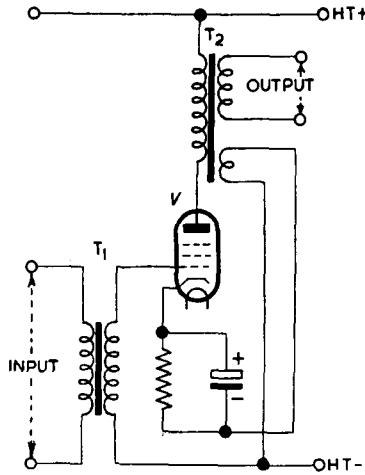

Fig. 28. The Use of a Tertiary Winding on the Output Transformer to give Voltage Feedback

$$T = \sqrt{\frac{\text{optimum load}}{\text{external load}}}$$

In this example

$$\begin{aligned} T &= \sqrt{\frac{40,000}{300}} \\ &= 11.5 : 1 \end{aligned}$$

- (b) Since the output transformer has a step-down turns ratio of 11.5 : 1, the gain from input-transformer secondary to anode must be 115 times to give the wanted overall gain.  
 The gain of the valve from grid-cathode to anode is given by

$$\begin{aligned} A &\approx g_m R_L \\ &= \frac{5}{1,000} \times 40,000 \\ &= 200 \end{aligned}$$

## NEGATIVE FEEDBACK

The gain from input-transformer secondary to anode is given by

$$A' = \frac{A}{1 + A\beta} \quad (\text{see expression 49})$$

This can be written in the form

$$\beta = \frac{A - A'}{AA'}$$

Putting  $A = 200$  and  $A' = 115$

$$\begin{aligned} \beta &= \frac{200 - 115}{200 \times 115} \\ &= \frac{1}{270} \end{aligned}$$

The only attenuation present in the feedback circuit is the step-down ratio of the output transformer. Thus this component should have a step-down ratio of 270 : 1 with respect to the tertiary winding.

(c) The  $r_a'$  of the valve in Fig. 28 is given by

$$\begin{aligned} r_a' &= \frac{r_a}{1 + \mu\beta} \\ &= \frac{1,000,000}{1 + 5,000 \times \frac{1}{270}} \\ &= \frac{1,000,000}{19.5} \\ &\approx 50,000 \text{ ohms} \end{aligned}$$

The output transformer has an impedance ratio from primary to secondary of 40,000 : 300 and thus the output impedance is given by

$$\begin{aligned} r_a' &= \frac{50,000 \times 300}{40,000} \\ &= 375 \text{ ohms.} \end{aligned}$$

3. Fig. 29 shows a two-valve amplifier in which the feedback voltage is derived from a tertiary winding on the output transformer and is applied to the cathode of V1. This circuit is used in the *MPA/1* amplifier.

## NEGATIVE FEEDBACK

Let the constants of  $V_1$  be as follows :—

$$\begin{aligned} r_a &= 1,000,000 \text{ ohms} \\ \mu &= 5,000 \\ g_m &= 5 \text{ mA/volt} \\ \text{voltage gain} &= 100 \end{aligned}$$

and of  $V_2$

$$\begin{aligned} r_a &= 50,000 \text{ ohms} \\ \mu &= 500 \\ g_m &= 10 \text{ mA/volt} \\ \text{optimum load} &= 5,000 \text{ ohms} \end{aligned}$$

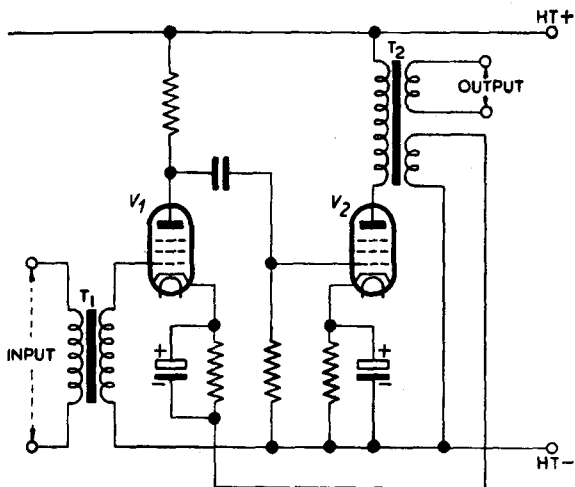

**Fig. 29.** Voltage Feedback Applied over Two Stages of Amplification from a Tertiary Winding

The amplifier is to feed a loudspeaker of 15 ohms impedance and to give the required electrical damping must have an output impedance of 2 ohms.

It is required to find :

- (a) the turns ratio of the output transformer with respect to the secondary winding,
  - (b) the turns ratio of the output transformer with respect to the tertiary winding,
  - (c) the gain of the amplifier from input-transformer secondary to the anode of  $V_2$ ,
  - (d) the peak input signal at the input-transformer secondary for maximum power output.
- (a) The turns ratio of the output transformer with respect to the secondary winding is given by the expression

## NEGATIVE FEEDBACK

$$\begin{aligned}
 T &= \sqrt{\frac{\text{optimum load of } V_2}{\text{external load}}} \\
 &= \sqrt{\frac{5,000}{15}} \\
 &= 18 : 1
 \end{aligned}$$

- (b) If the output impedance is to be 2 ohms at the secondary of the output transformer, it will be  $2 \times T^2$  ohms at the primary, where  $T^2 = 5,000/15$  as already shown. Thus  $r_a'$  must be

$$\begin{aligned}
 &2 \times T^2 \\
 &= 2 \times \frac{5,000}{15} \\
 &= 670 \text{ ohms}
 \end{aligned}$$

From expression (61) the effective anode a.c. resistance of  $V_2$  is given by

$$r_a' \approx \frac{1}{g_m A \beta}$$

where  $g_m$  = mutual conductance of  $V_2$ ,

$A$  = stage gain of  $V_1$  from grid cathode to anode

and  $\beta$  = total attenuation in the feedback circuit.

This can be written in the form

$$\begin{aligned}
 \beta &= \frac{1}{g_m A r_a'} \\
 \therefore \beta &= \frac{1,000}{10 \times 100 \times 670} \\
 &= \frac{1}{670}
 \end{aligned}$$

The only attenuation present in the feedback circuit is that due to the step-down turns ratio of the primary to the tertiary winding on the output transformer. This turns ratio should thus be 670 : 1. In practice, the calculation of output resistance is more complicated than the above argument would suggest, since the resistance of the primary and secondary windings of the output transformer must be added to the output impedance. For this reason, the feedback must be increased to reduce still further the amplifier output impedance so that the sum of all the resistances gives the desired output impedance.

## NEGATIVE FEEDBACK

- (c) It was shown on p. 26 that the gain of an amplifier with considerable feedback is approximately equal to  $1/\beta$ . Thus the gain of the amplifier in Fig. 29 may be taken as approximately 670 times, from the input-transformer secondary to the anode of V2.
- (d) If V2 has an anode supply of 300 volts, the maximum amplitude of anode potential swing will be about 250 volts and to give this amplitude the peak signal at the input-transformer secondary must be  $250/670$ , i.e., 0.4 volt approximately.

### THE CATHODE FOLLOWER

#### General Considerations

Fig. 30 illustrates the circuit of the simplest type of cathode follower. The load resistor  $R_l$  is included in the cathode circuit and the output signal appears between cathode and h.t. negative. The grid leak  $R_{gl}$  is connected between grid and h.t. negative and the input signal is applied across it. The grid-cathode signal is the difference between the input and output signals. Thus the cathode follower is an example of voltage negative feedback in which the whole of the output voltage is used as negative feedback, i.e.,  $\beta = 1$ .

$$\therefore V_{in} = V_{gk} + V_{out}$$

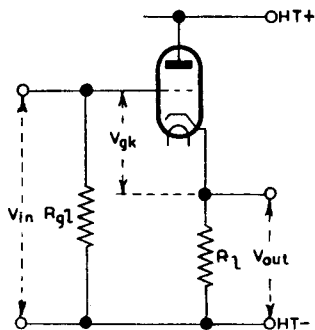

Fig. 30. Simplest Form of Cathode Follower

The characteristics of a valve used in this circuit may be deduced as follows. The solid curves in Fig. 31 are the characteristics of a triode valve for values of  $V_{gk}$ . The valve is assumed to have a fixed h.t. supply of 300 volts and its load is in the cathode circuit. If the p.d. between anode and cathode is  $V_{ak}$  volts, the p.d. between cathode and h.t. negative ( $V_{out}$ ) is  $(300 - V_{ak})$  volts. The abscissae in Fig. 31 represent the value of  $V_{out}$  and  $V_{ak}$ , and in order that the characteristics shall appear the usual way round, the value of  $V_{out}$  is arranged to increase positively from right to left.



## NEGATIVE FEEDBACK

Consider the characteristic for  $V_{gk} = 0$  at  $V_{out} = 200$  volts (point P). If the cathode potential is 200 volts positive with respect to h.t. negative, the signal  $V_{in}$  applied between grid and h.t. negative must also be + 200 volts. Consequently, point P lies on the new characteristic for  $V_{in} = + 200$ . If  $V_{gk} = - 5$  volts and  $V_{in} = + 200$  volts,  $V_{out}$  must be + 205 volts. This does not, however, indicate a gain of greater than unity because  $V_{in}$  and  $V_{out}$  in this example are steady voltages. Hence  $V_{gk} = - 5$  and  $V_{om} =$

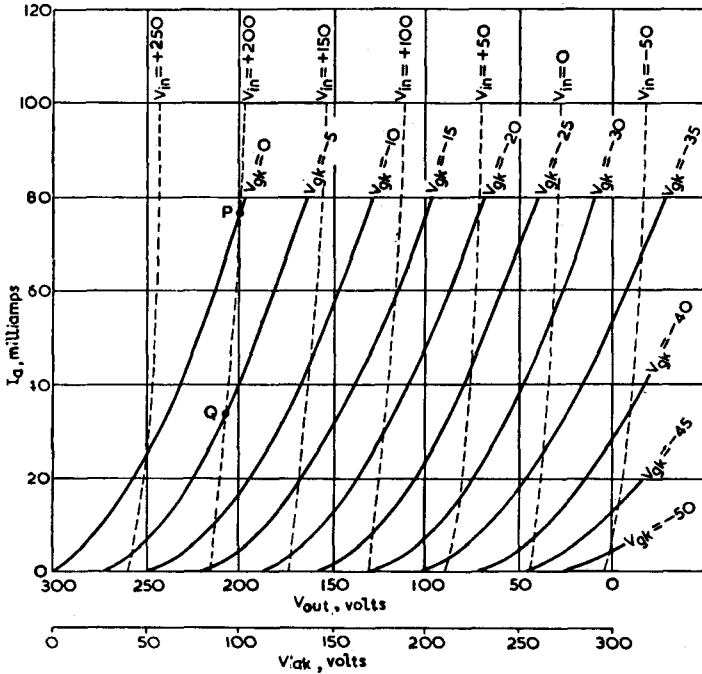

Fig. 31. Effective  $I_a - V_a$  characteristics of a Cathode Follower

+ 205 are the co-ordinates of another point, Q, lying on the characteristic for  $V_{in} = + 200$  volts. Similarly the position of other points may be deduced, using the relationship

$$V_{out} = V_{in} - V_{gk}$$

The characteristics of the valve with 100 per cent. feedback are given by the dotted lines in Fig. 31. These are nearly upright, indicating a very low value of  $r_a'$  and are much straighter and more nearly parallel than before the application of negative feedback, showing a considerable reduction in harmonic distortion.

## NEGATIVE FEEDBACK

If the valve in Fig. 30 is a pentode or tetrode it will behave as a triode, even in the absence of negative feedback, because the load is in the cathode circuit and carries the total cathode current which includes the anode and screen contributions.

A phase-splitter stage consisting of a triode valve with equal load resistors in anode and cathode leads has something in common with Fig. 30. It is a circuit in which  $\beta = 0.5$ , and the output impedance of the cathode circuit is very low due to the large amount of voltage feedback present. The output impedance of the anode circuit, however, is very high as a consequence of the current feedback produced by the resistance in the cathode circuit. The tendency of a reactive load coupled to the anode circuit will be to increase attenuation distortion due to reactance variation, whilst the cathode circuit will tend to reduce it.

### Simple Cathode Follower

In this particular form of cathode follower (Fig. 30)  $R_l$  acts as automatic-bias resistor and as anode load. To give a reasonable anode current the resistance  $R_l$  must be a small fraction of the anode a.c. resistance of the valve and the stage gain of the amplifier is low with respect to  $V_{gk}$  and even lower with respect to  $V_{in}$ . More important than this, the output of a valve working into a small load is very limited and the application of negative feedback does not materially increase the undistorted output available. Thus the cathode follower of Fig. 30 can accept only a small input signal. More details of the signal-handling capacity of such stages appear elsewhere.\*

The output impedance of the circuit is given by  $r_a/(1 + \mu\beta)$  where  $\beta = 1$ .

$$\therefore r_a' = \frac{r_a}{1 + \mu} \quad \dots \quad \dots \quad \dots \quad \dots \quad (71)$$

If, as is usual,  $\mu$  is large compared with unity, this may be written

$$r_a' \simeq \frac{r_a}{\mu} = \frac{1}{g_m} \quad \dots \quad \dots \quad \dots \quad (72)$$

In practice, values of  $g_m$  of the order of 5 mA/V are quite common and thus this circuit may have an effective anode a.c. resistance of about 200 ohms. This low  $r_a'$  is one of the most useful properties of the cathode follower for it implies a low output impedance.

If  $R_l$  in Fig. 30 represents a direct-coupled external load, the output impedance of the cathode follower is simply  $r_a'$  ( $= 1/g_m$ ) but if a transformer of turns ratio  $T : 1$  is included between cathode circuit and load, the output

---

\* S. W. Amos, "Valves with Resistive Loads; Output Signal-handling Capacity" *Wireless Engineer*, p. 119, April, 1949.

## NEGATIVE FEEDBACK

impedance becomes  $r_a'/T^2$ . The inclusion of the output transformer is useful because  $T$  may be chosen to allow the valve to work into the correct value of optimum load. Under this condition it can supply and accept large signals without distortion. In such a circuit the resistance in the cathode circuit i.e., that of the transformer primary, which provides grid bias should not be allowed to exceed the correct value if maximum signal-handling capacity is to be obtained.

If  $R_l$  is a resistor within the amplifier and if the external load is connected directly in parallel with it, the output impedance is that of  $r_a'$  and  $R_l$  in parallel, i.e.,  $r_a'R_l/(r_a' + R_l)$ .

The stage gain  $A'$  i.e.,  $V_{out}/V_{in}$  is given by  $A/(1 + A\beta)$  where  $\beta = 1$

$$\therefore A' = \frac{A}{1 + A} \quad \dots \quad \dots \quad \dots \quad (73)$$

where  $A$  is the stage gain measured with respect to  $V_{gk}$ . If  $A$  is large compared with unity the stage gain of the cathode follower is approximately one. If  $R_l$  is small, the stage gain may be appreciably less than one; for example if  $A$  is equal to one,  $A'$  is 0.5 (from 73).

The input impedance of the circuit illustrated in Fig. 30 is equal to  $R_{gl}$  and may be given any desired value within certain limits. It may be, for example, 1 megohm. Thus the stage may be regarded as equivalent to a transformer having approximately unity turns ratio but with a high input impedance and a low output impedance. These properties make the circuit particularly useful in vision-frequency amplification and further details of this application can be found in the Television Instruction Book.

### Alternative Form of Cathode Follower

Fig. 32 shows a more complex type of cathode follower circuit in which a separate resistor is used for providing cathode bias.  $R_l$  and  $R_b$  constitute the load,  $R_b$  is the bias resistor and the grid leak  $R_{gl}$  is returned to their junction. This modification gives the circuit of Fig. 32 quite different properties from that of Fig. 30. For example, the valve in Fig. 32 may operate with its normal value of load and grid bias and can accept an input equal to the maximum anode-potential swing encountered in the normal RC-coupled circuit. The input circuit of Fig. 32 resembles that of Fig. 25 and has the property that the input resistance may exceed the value of  $R_{gl}$ , a property not possessed by the more elementary circuit of Fig. 30. The input resistance depends, however, on the resistance of the load to which the output of the cathode follower is connected. Because the grid leak is not returned to h.t. negative in Fig. 32 the feedback fraction is dependent on the generator resistance of the signal source to which the cathode follower is connected and the feedback fraction is, in general, less than in Fig. 30. Thus the output impedance of the circuit (Fig. 32) is greater than that of

## NEGATIVE FEEDBACK

Fig. 30 and is dependent on the source resistance. These properties of the cathode follower are borne out by the following expressions for the gain, output resistance and input resistance, which are deduced in Appendix 3.

### Gain of Cathode Follower

The gain of the cathode follower (Fig. 32) measured by the expression  $V_{out}/V_{in}$  is shown to be equal to  $A/(1 + A)$  but, measured with respect to the generator voltage, is given by

$$\frac{V_{out}}{V_{gen}} = \frac{A \beta_2}{1 + A [\beta_2 (1 - \beta_1) + \beta_1]} \quad \dots \quad (74)$$

where 
$$\beta_1 = \frac{R_b}{R_b + R_l}$$

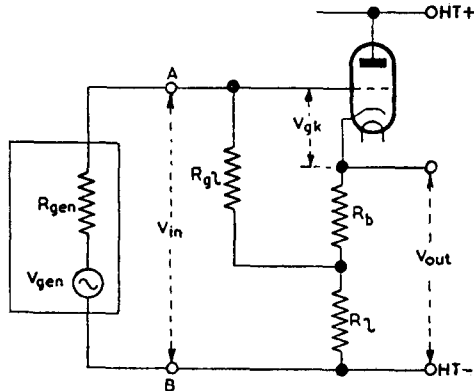

Fig. 32. Cathode Follower Circuit in which a Separate Resistor is used for Grid Bias

and 
$$\beta_2 = \frac{R_{gl}}{R_{gen} + R_{gl}}$$

The gain thus depends on the value of  $A$ , on the ratio of  $R_b$  to  $R_l$  and on the ratio of  $R_{gl}$  to  $(R_{gl} + R_{gen})$ .

The signal source feeding a cathode-follower stage generally has a low internal resistance and  $R_{gen}$  is small compared with  $R_{gl}$ . Thus,  $\beta_2$  is very nearly equal to unity and may be taken as unity to obtain approximate results. If  $\beta_2 = 1$  expression (74) becomes

$$\frac{V_{out}}{V_{gen}} = \frac{A}{1 + A}$$

## NEGATIVE FEEDBACK

A significant feature of this expression is that  $\beta_1$  does not occur in it. This means that, for a low resistance signal source, the ratio of  $R_b$  to  $R_l$  has no effect on the gain. If  $R_{gen}$  is not small compared with  $R_{gl}$ , the value of  $\beta_1$  does alter the gain to a very small extent but the effect can usually be neglected. Hence, there is no change in gain by decoupling  $R_b$  with a large capacitor to suppress feedback due to this component. As will be shown, however, the ratio of  $R_b$  to  $R_l$  does affect the input impedance of the circuit.

### Output Impedance of Cathode Follower

As proved in Appendix 3 the effective  $r_a$  in Fig. 32 is given by

$$r_a' = \frac{r_a}{1 + \mu\beta_2(1 - \beta_1) + \mu\beta_1} \quad \dots \quad \dots \quad (75)$$

and this, too, depends on the values of  $R_l$ ,  $R_b$ ,  $R_{gl}$  and  $R_{gen}$ . If, as is usual,  $R_{gen}$  is small compared with  $R_{gl}$ ,  $\beta_2$  is nearly unity. To obtain an approximate result put  $\beta_2$  equal to one in (75).

$$r_a' = \frac{r_a}{1 + \mu} \quad \dots \quad \dots \quad \dots \quad (76)$$

This is the result obtained for Fig. 30. Since  $\beta_1$  does not feature in this expression, the ratio of  $R_b$  to  $R_l$  has no effect on  $r_a'$  and the output impedance of the circuit.

If  $R_{gen}$  is not small compared with  $R_{gl}$ , the effective feedback voltage is less than  $V_{out}$  and  $r_a'$  is greater than  $r_a/(1 + \mu)$ . In these circumstances  $\beta_1$  has the effect of slightly increasing  $r_a'$ .

The relationship between  $R_l$ ,  $r_a'$  and output impedance is as discussed on p. 58.

### Input Impedance of Cathode Follower

The input impedance (Fig. 32) is in general given by

$$R_{in} = R_{gl} \cdot \frac{1 + A}{1 + A\beta_1} \quad \dots \quad \dots \quad \dots \quad (77)$$

If  $R_b$  is shunted by a large capacitance the impedance between cathode and the lower end of the grid leak is made very small and  $\beta_1$  tends to zero. If  $\beta_1 = 0$  expression (77) gives the input impedance as  $R_{gl}(A + 1)$ . As  $A$  may easily be 30 or more, this circuit can have an extremely high input impedance, many times greater than the value of the grid leak. If  $R_{gl}$  is 1 megohm and  $A$  is 30, the input impedance may be taken, for all normal purposes, as infinite.

If, as in Fig. 32,  $R_b$  is not decoupled,  $\beta_1$  is given by

## NEGATIVE FEEDBACK

$$\beta_1 = \frac{R_b}{R_b + R_l}$$

As  $R_b$  is usually very small compared with  $R_l$ ,  $\beta_1$  is approximately given by

$$\beta_1 = \frac{R_b}{R_l}$$

In any triode amplifier the gain  $A$  from grid-cathode to anode is given approximately by  $R_l/R_b$ . This result is proved in Appendix 4. Thus  $\beta_1$  may be replaced by  $1/A$ . Making this substitution in (77) gives

$$R_{in} = R_{gl} \cdot \frac{A + 1}{2} \dots \dots \dots (78)$$

Thus the input impedance is halved by removing the bypass capacitor from  $R_b$ . If  $A$  and  $R_{gl}$  are very large, it may well be that the reduction in input impedance is unimportant, but in other circumstances the reduction may be undesirable.

It is not immediately apparent from expression (77) that the output load of the circuit has an effect on the input impedance. If the cathode-follower circuit is terminated by a resistance equal to  $R_l$ , the valve load is approximately halved and the gain that the valve has in respect to an input between grid and cathode is reduced. If  $A$  is reduced in (77), the input resistance is also reduced. If the output load is very small indeed,  $A$  tends to zero and from (77)  $R_{in}$  tends to  $R_{gl}$ . The elementary form of cathode follower illustrated in Fig. 30 does not suffer from this effect because the cathode resistor is very small.

## CURRENT FEEDBACK

### General Considerations

The above discussions are devoted entirely to circuits in which the feedback voltage is directly proportional to the p.d. across the output load. Fig. 33 illustrates a circuit which provides a feedback voltage directly

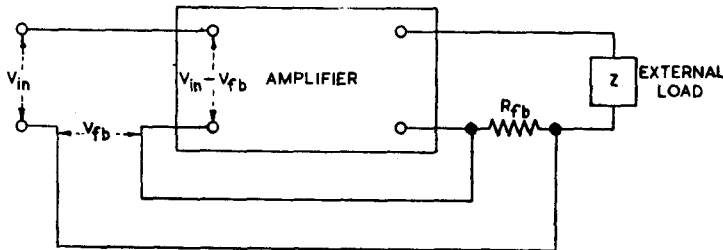

Fig. 33. Basic Connections for Series-connected Current Feedback

## NEGATIVE FEEDBACK

proportional to the current,  $I$ , in the output load,  $Z$ . Such a circuit is referred to as a *current feedback* circuit.

As with voltage feedback, current feedback reduces the gain of an amplifier, together with any attenuation or harmonic distortion occurring within the feedback loop. Fig. 33 shows that the feedback resistor  $R_{fb}$  forms part of the output load and absorbs some of the output power of the

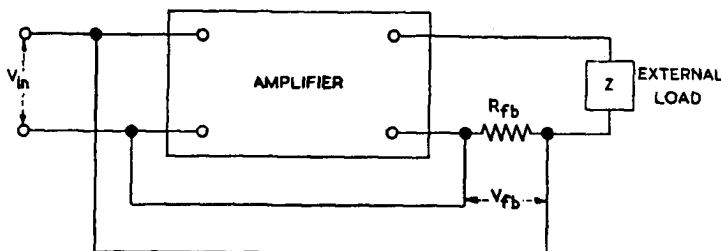

Fig. 34. Basic Connection for Parallel-connected Current Feedback

amplifier. If current feedback is applied to the output stage, this power loss may be appreciable, unless  $R_{fb}$  is made small compared with  $Z$ . Normally, however, current feedback is applied to voltage-amplifying stages and  $R_{fb}$  is usually small compared with the anode load.

Current feedback may be series-connected as shown in Fig. 33 or parallel-connected as shown in Fig. 34. These connections modify the value of  $\beta$  and are discussed more fully in a later section.

### Effect of Current Feedback on Gain

The following is a general treatment of the effect of current feedback on gain. The result obtained applies to all amplifiers with current feedback provided the correct interpretation is put on  $\beta$  and on gain. This provision is particularly important in parallel-connected feedback where the value of  $\beta$  is not obvious. Detailed considerations, based on practical circuits, are dealt with later in this section.

Suppose the amplifier (Fig. 33) contains a single valve with parameters  $\mu$ ,  $g_m$  and  $r_a$ . The grid-cathode signal is made up of  $V_{in}$ , the external input signal, and  $V_{fb}$ , the feedback voltage. Hence

$$V_{gk} = V_{in} - V_{fb}$$

the negative sign prefacing  $V_{fb}$  indicating that the feedback voltage is negative and in opposition to the external input signal.

Substituting  $(V_{in} - V_{fb})$  for  $V_{gk}$  in

$$I = \frac{\mu V_{gk}}{r_a + Z + R_{fb}}$$

## NEGATIVE FEEDBACK

gives 
$$I = \frac{\mu(V_{in} - V_{fb})}{r_a + Z + R_{fb}} \quad \dots \quad \dots \quad \dots \quad (79)$$

The feedback voltage  $V_{fb}$  is developed across  $R_{fb}$  by the a.c. component,  $I$ , of the anode current.

Thus

$$V_{fb} = IR_{fb} \quad \dots \quad \dots \quad \dots \quad \dots \quad (80)$$

Substituting for  $V_{fb}$  from (80) in (79)

$$I = \frac{\mu(V_{in} - IR_{fb})}{r_a + Z + R_{fb}}$$

Solving for  $I$

$$I = \frac{\mu V_{in}}{r_a + Z + (\mu + 1) R_{fb}} \quad \dots \quad \dots \quad (81)$$

The output voltage,  $V_{out}$ , is the p.d. caused by  $I$  in flowing through  $Z$ .

$$\therefore V_{out} = IZ \quad \dots \quad \dots \quad \dots \quad \dots \quad (82)$$

Substituting for  $I$  from (81) in (82) and re-arranging

$$\frac{V_{out}}{V_{in}} = A' = \frac{\mu Z}{r_a + Z + (\mu + 1) R_{fb}}$$

Dividing numerator and denominator by  $(r_a + Z)$

$$A' = \frac{\frac{\mu Z}{r_a + Z}}{1 + \frac{(\mu + 1) Z \cdot R_{fb}}{(r_a + Z) \cdot Z}}$$

But  $\mu Z / (r_a + Z) = A$ , the gain of the valve with respect to an input signal applied between grid and cathode. Neglecting 1 in comparison with  $\mu$

$$\therefore A' = \frac{A}{1 + A\beta} \quad \dots \quad \dots \quad \dots \quad (83)$$

where  $\beta = R_{fb}/Z$ . This expression is the same as that obtained for voltage feedback (equation 59). If the feedback is considerable (i.e., if  $\beta \gg 1/A$ ), the voltage gain of the amplifier is reduced approximately to  $1/\beta$ , i.e., to  $Z/R_{fb}$ . This is a particularly convenient expression, as it frequently enables the gain of an amplifier to be estimated by inspection of the values of the feedback and anode-circuit components.

### Effect of Current Feedback on Output Impedance

The relationship between output impedance and effective anode a.c. resistance was made clear on p. 33. The effect of current feedback on  $r_a$



## NEGATIVE FEEDBACK

and hence on output impedance may be evaluated as follows:—

Comparison of equation (81) with

$$I = \frac{\mu V_{gk}}{r_a + Z}$$

shows that the amplification factor,  $\mu$ , is not affected by current feedback but that the  $r_a$  has been increased according to the equation

$$r_a' = r_a + (\mu + 1) R_{fb} \quad \dots \quad (84)$$

Voltage feedback, it will be recalled, decreases  $r_a$  (see p. 33).

As already pointed out, it is usually desirable to have a low output impedance in amplifiers which have to drive electro-mechanical devices, and voltage feedback is particularly suited to the needs of such amplifiers. For so-called voltage amplifying stages, however, which are required to give the greatest undistorted output voltage rather than to deliver appreciable power, current feedback is quite a satisfactory method of reducing distortion. Sometimes current feedback is used in addition to voltage feedback in an output stage in order to obtain a specific value of output impedance which cannot be conveniently obtained with voltage feedback alone. Some information about these mixed feedback circuits is given later.

Since current feedback increases the effective anode a.c. resistance of a valve, it increases the ratio of output impedance to output load, and thus tends to cause constant-current operation. In other words, in an amplifier with considerable current feedback the output current tends to be independent of the value of the output load and is decided entirely by the input voltage and the amplification. Voltage feedback, it will be recalled, tends to give constant-voltage operation.

If several valves are included within the feedback loop the effective value of  $r_a$  becomes

$$r_a' = r_a + (\mu A + 1) R_{fb}$$

where  $A$  = the stage gain of the amplifier from the point of injection of the feedback voltage to the grid of the final valve and  $\mu$  is the amplification factor of the last valve.

### Instability and Current Feedback

In its most usual form current feedback is applied between output and input circuits of a single-valve amplifier and the feedback employed is generally insufficient to cause instability. Current feedback can, however, be applied over several stages of amplification and instability is then possible at frequencies outside the pass-band of the amplifier. The precautions necessary to prevent instability were discussed in the section dealing with voltage feedback.

## NEGATIVE FEEDBACK

### Effective Characteristics of a Valve with Current Feedback

When current feedback is applied to a valve, the effective anode a.c. resistance is increased but the amplification factor is unaffected. This can be illustrated by constructing  $I_a - V_a$  characteristics for various values of  $V_{in}$  which can be determined experimentally with the aid of a circuit such as Fig. 35 which shows the simplest method of applying current feedback to a

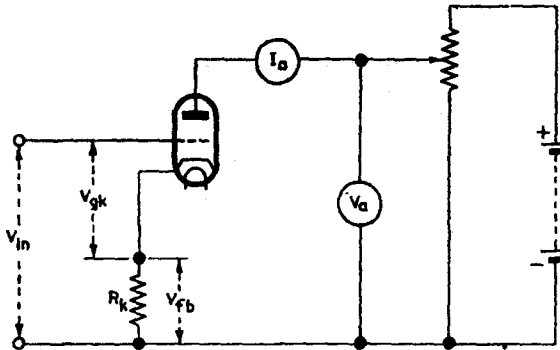

Fig. 35. Circuit for Determining the Effective  $I_a - V_a$  Curves of a Valve with Current Feedback

valve; the feedback is obtained by the omission of the bypass capacitor normally connected in parallel with the automatic bias resistor  $R_b$ . It is also possible to deduce these characteristics from the  $I_a - V_a$  characteristics

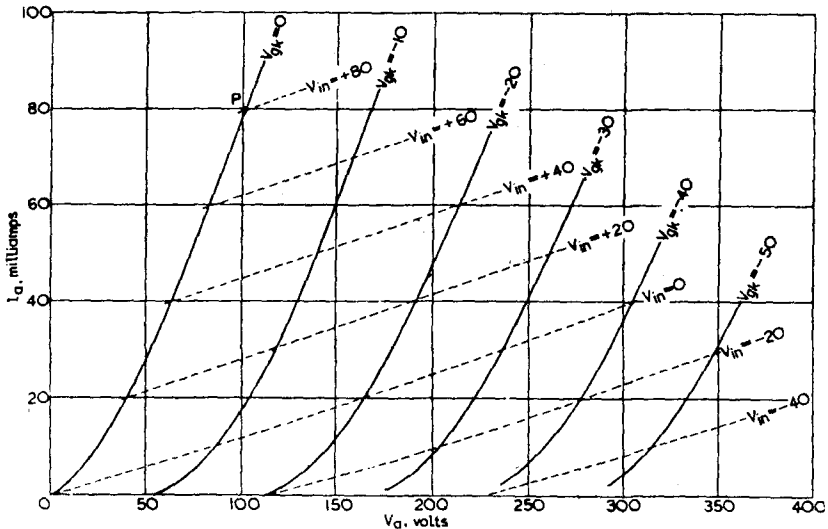

Fig. 36. Effective  $I_a - V_a$  Curves (shown dotted) of a Valve with Current Feedback

## NEGATIVE FEEDBACK

by a method somewhat similar to that described on page 36.

In Fig. 36 the solid curves are the  $I_a - V_a$  characteristics of a triode valve for values of  $V_{gk}$ . Suppose current feedback is applied to it, as shown in Fig. 35,  $R_k$  being 1,000 ohms. When  $V_a = 100$  volts and  $V_{gk} = 0$  (point P in Fig. 36)  $I_a = 80$  mA and hence  $V_{fb} = 80$  volts, making the cathode potential positive with respect to h.t. negative. Clearly the input voltage,  $V_{in}$  must be + 80 volts with respect to h.t. negative to make  $V_{gk} = 0$ . Thus P is one point on the characteristic for  $V_{in} = + 80$  volts. For all points lying on the horizontal line for which  $I_a = 80$  mA, the value of  $V_{in}$  is 80 volts more than  $V_{gk}$ .

By repeated use of the expression  $V_{in} = V_{gk} + I_a R_k$  it is possible to deduce the characteristics of the valve for the chosen value of  $R_k$ . They are shown as dotted lines in Fig. 36.

The dotted curves are more nearly horizontal than the solid ones, showing an increase in the effective value of  $r_a$ , and they are also straighter, more parallel and of more uniform spacing, showing a decrease in harmonic distortion. The vertical spacing between the dotted curves is much closer than for the solid ones, for equal increments in grid potential, showing that the gain of the valve has been decreased by the application of feedback. The horizontal spacing, however, which decides  $\mu$ , is unchanged by current feedback, this agreeing with the result deduced on page 64.

### Current Feedback from the Anode Circuit of a Valve

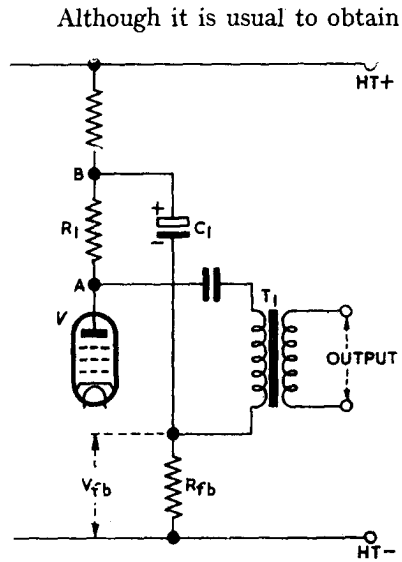

Fig. 37. Current Feedback Obtained from the Anode Circuit of a Valve

in the cathode circuit of a valve, it can be obtained by other methods, one of which is shown in Fig. 37. This circuit is used in the AMC/2 amplifier. The a.c. component of the anode current of the valve  $V$  divides at A, some of it going into the primary winding of the output transformer, the remainder, after passing through  $R_1$ , divides again at B where most of it flows into the decoupling capacitor  $C_1$ . Since  $C_1$  and the primary winding of  $T_1$  are both returned to the resistor  $R_{fb}$ , most of the a.c. component passes through  $R_{fb}$  and the p.d. developed may be used for feedback purposes. The effective value of the feedback resistance is less than  $R_{fb}$  because the decoupling resistor is effectively in parallel with it, but in a practical circuit the decoupling

## NEGATIVE FEEDBACK

resistor will probably be large compared with  $R_{fb}$  and the reduction is negligible. The anode load of the valve is made up of the parallel combination of  $R_1$  and the load reflected into the primary of T1. The p.d. developed across  $R_{fb}$  may be applied to the valve V or to an earlier stage, provided correct phase relationship is secured and it may be connected in series or in parallel with the valve input circuit.

### Gain Control by Current Feedback

The current feedback obtained by omitting the bypass capacitor from the cathode resistor providing automatic bias is usually less than 10 db. This feedback could be made variable but would not constitute an effective gain control because of the limited range. It is, therefore, necessary, before variable current feedback can be used as a gain control, to devise a circuit giving more current feedback than is provided by the bias resistor. Such a circuit is shown in Fig. 38.

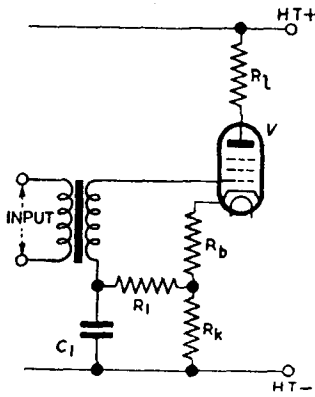

Fig. 38. Circuit giving more Current Feedback than is provided by the Bias Resistor

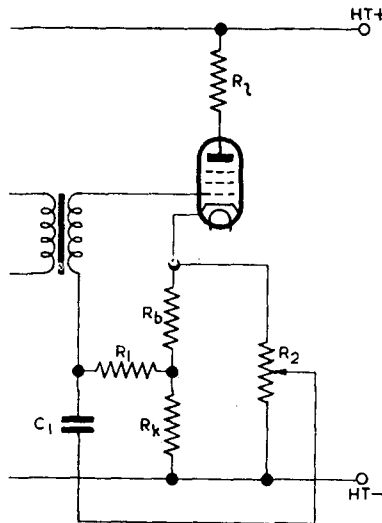

Fig. 39. Gain Control by Variable Current Feedback

In this circuit  $R_1$  should greatly exceed  $R_k$  and the reactance of  $C_1$  should be small compared with  $R_1$  throughout the pass-band of the amplifier. Neither  $R_b$  nor  $R_k$  are decoupled and both provide current feedback but because the grid circuit is returned to the junction of  $R_b$  and  $R_k$ , only  $R_b$  is effective in providing bias. Thus by increasing  $R_k$ , current feedback can

## NEGATIVE FEEDBACK

be increased without appreciably affecting the bias. This circuit is used in the circuit of V1 in amplifiers *TV/20*, *D/8B-G*, *D/11*, *B/14A* and *MNA/1*. The circuit of Fig. 38 can be modified to give gain control by variable current feedback as shown in Fig. 39.  $C_1$  is returned to the slider of a potentiometer  $R_2$  connected across the cathode circuit. The value of  $R_2$  should exceed  $(R_b + R_k)$  otherwise a reduction in current feedback and bias results. Alternatively the values of  $R_b$ ,  $R_k$  and  $R_2$  can be chosen to give the desired amount of feedback and a capacitor of reactance small compared with  $R_2$  inserted in series with  $R_2$  to prevent any effective reduction in the value of  $R_b$ , which would alter the value of the grid bias. When the slider of the potentiometer is at the bottom of its travel, Fig. 39 is identical with Fig. 38, feedback is a maximum and gain a minimum. If the slider is at the top of its travel there is no feedback and gain is a maximum. As in voltage feedback systems, the total variation in gain possible with such circuits, is limited to a maximum of about 30 db. Amplifiers using a circuit similar to this are the *OBA/8* (V1), *D/9* (V1), *D/11* (V1), *A/11* (V1) and the *APM/1* (V1).

### Tone Control by Current Feedback

It is possible to obtain almost any desired shape of frequency response curve from an amplifier by the inclusion of reactive elements in the feedback chain. One example, taken from the circuit of the *OBA/8* amplifier is given in Fig. 40. The diagram shows the essential connections of valve V2.

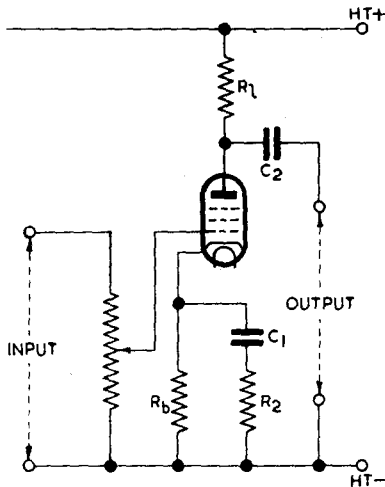

Fig. 40. Tone Control by means of Current Feedback

$R_b$  is the automatic bias resistor which also provides current feedback;  $\beta$  is made to vary with frequency by the inclusion of the components  $R_2C_1$ , the values of which are chosen to give a frequency response rising above about 8,000 c/s.

Suppose  $R_b = R_2$  (this is approximately true). At very low frequencies when the reactance of  $C_1$  is very great, the value of  $\beta$  is given by  $R_b/R_1$ , where  $R_1$  is the value of the anode load of the valve. At very high frequencies, when the reactance of  $C_1$  may be neglected, the effective value of the feed-

## NEGATIVE FEEDBACK

back resistor in the cathode circuit is  $R_b/2$  and  $\beta = R_b/2R_i$ . If the stage gain of the valve is decided entirely by the constants of the feedback circuit there will be an increase of 6 db in gain at the very high frequencies compared with the gain at low frequencies. The capacitance of  $C_1$  decides the frequency at which the rise in gain begins. If it occurs at, say, 100 c/s, the effect of the tone control circuit may be described as *bass cut*. If, as in the *OBA/8*, the rise is at a high audio-frequency, the frequency response is an example of *top-lift*. A similar tone control circuit is used in the *D/8* amplifiers B to G.

Another interesting example of the use of frequency-discriminating current feedback occurs in the design of the *MPA/1* amplifier. The automatic bias resistor  $R_b$  (Fig. 41) of  $V_1$  is shunted by a capacitor  $C_1$ , the reactance of which is comparable with the value of  $R_b$  at a supersonic frequency. The result is that this network tends to give a frequency response which begins to rise immediately above the audio-frequency band. The purpose of this circuit arrangement is to limit the steepness of the fall of the over-all frequency response of the amplifier, and avoid instability due to the main voltage-feedback circuit.

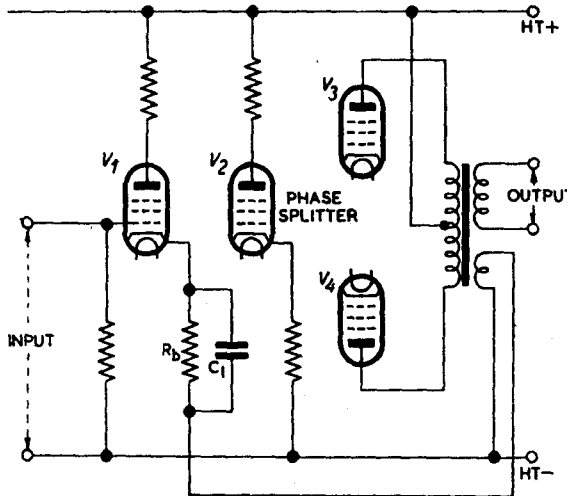

Fig. 41. Use of Current Feedback to avoid Instability due to Voltage Feedback

### Series-connected Current Feedback. More Detailed Considerations

#### 1. Effect on Gain

Fig. 42 illustrates the simplest circuit that may be used for the provision of current feedback; there is no bypass capacitor in parallel with  $R_k$  which, therefore, provides biasing and feedback potentials.  $R_k$  thus corresponds

## NEGATIVE FEEDBACK

with  $R_{fb}$  in Fig. 33 and the formulae developed in the section headed General Considerations apply to Fig. 42. For example, the gain of the amplifier is given by expression (83) i.e.

$$A' = \frac{V_{out}}{V_{in}} = \frac{A}{1 + A\beta_1} \quad \dots \quad \dots \quad (85)$$

where  $A = g_m R_l =$  gain of the valve with respect to grid-cathode signals and  $\beta_1 = R_k / (R_k + R_l)$ . Normally  $R_l$  greatly exceeds  $R_k$  and  $\beta_1$  may be taken as  $R_k / R_l$  with very little error.

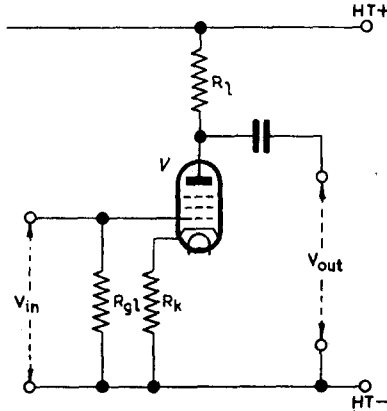

Fig. 42. Simple Example of Series-connected Current Negative Feedback in which the Cathode Resistor  $R_k$  functions simultaneously as a Feedback and as a Cathode-biasing Component

Substituting  $A = g_m R_l$  and  $\beta_1 = R_k / R_l$  in (85) gives

$$A' = \frac{g_m R_l}{1 + g_m R_k} \quad \dots \quad \dots \quad \dots \quad (86)$$

If  $g_m R_k$  greatly exceeds unity (86) becomes

$$A' = \frac{R_l}{R_k} \quad \dots \quad \dots \quad \dots \quad \dots \quad (87)$$

Thus the gain of a valve with considerable current feedback is approximately equal to the anode load value divided by the bias-resistor value.

When current feedback is applied to a pentode by use of an unbypassed cathode resistor, the feedback voltage is due to the anode current and screen current in the cathode circuit. Thus expression (86), which takes account of anode current only, underestimates the amount of feedback present. To be accurate, the gain with feedback is given by

## NEGATIVE FEEDBACK

$$A' = \frac{g_m R_l}{1 + (g_m + g_s) R_k}$$

where  $g_s$  = conductance of the screen circuit, i.e., the change in screen current for a 1-volt change in grid potential. Practical values of  $g_s$  are of the order of  $0.2 g_m$  to  $0.3 g_m$  and the error introduced by neglecting  $g_s$  is not very great; for this reason and for the sake of simplicity, feedback due to screen current is neglected in later sections.

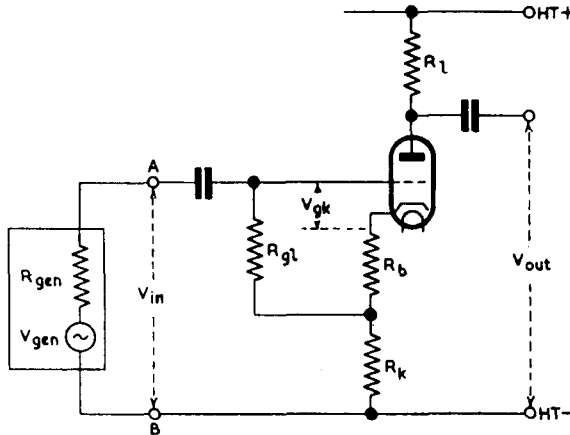

Fig. 43. A more complex Example of Series-connected Current Negative Feedback in which a separate Cathode Resistor is used for Bias.  $R_b$  is the Bias Resistor, but  $R_b$  and  $R_k$  both provide Current Feedback

Fig. 43 illustrates a modification of Fig. 42 in which a separate cathode resistor is used to provide grid bias. A similar circuit was given earlier in Fig. 38 and it was explained that this circuit arrangement gives more feedback than is provided by the bias resistor alone. The circuit also has something in common with Fig. 25. The lower end of the grid leak is connected to the junction of  $R_b$  and  $R_k$ ; this changed grid leak connection modifies the feedback fraction because the feedback voltage,  $V_{fb}$ , between grid and cathode is less than  $\beta_1 V_{out}$  developed across  $(R_b + R_k)$  and is given by

$$V_{fb} = \beta V_{out} \quad \dots \quad \dots \quad \dots \quad (88)$$

where

$$\beta = \frac{R_b + \beta_2 R_k}{R_l}$$

and

$$\beta_2 = \frac{R_{gl}}{R_{gl} + R_{scm}}$$



## NEGATIVE FEEDBACK

$R_{gl}$  and  $R_{gen}$  may be regarded as forming a potential divider connected across  $R_k$  (the reactance of the capacitor is neglected) and thus only a fraction of the signal p.d. developed across  $R_k$  is applied between the grid and cathode of the valve. This fraction is equal to  $R_{gl}/(R_{gl} + R_{gen})$ .

In many circuits the valve is fed from the anode of a previous valve via an RC-coupling circuit and  $R_{gen}$  is given by the value of the anode load resistor  $R_l$  and the anode a.c. resistance  $r_a$  of the previous valve in parallel. If  $r_a$  greatly exceeds  $R_l$ , as, for example, when the previous valve is a pentode,  $R_{gen}$  may be taken as approximately equal to  $R_l$ . In such a circuit  $R_{gen}$  is normally small compared with  $R_{gl}$  and practically the whole of the signal p.d. developed across  $R_k$  is returned to the grid circuit. In this instance  $\beta$  may be taken as equal to  $\beta_1$  with very little error and the gain of the circuit of Fig. 43 may be calculated from the formulae applicable to Fig. 42.

If  $R_{gen}$  is not small compared with  $R_{gl}$ ,  $\beta$  will depend on the value of  $R_{gen}$ , and the linearity of the amplifier, and its output impedance, will depend on the source impedance.

As shown in Appendix 5, the gain of the amplifier, measured between *input terminals* and *output terminals* is given by

$$A' = \frac{V_{out}}{V_{in}} = \frac{g_m R_l}{1 + g_m (R_b + R_k)} \quad \dots \quad \dots \quad (89)$$

This ratio is, of course, independent of the source impedance and in order to calculate the reduction in gain due to feedback the gain should be expressed by the ratio  $V_{out}/V_{gen}$ . As shown in Appendix 5 the gain of this circuit is given by

$$\frac{V_{out}}{V_{gen}} = \frac{g_m R_l \beta_2}{1 + g_m (R_b + \beta_2 R_k)} \quad \dots \quad \dots \quad \dots \quad (90)$$

### 2. Effect on Input Impedance

In general, series-connected current feedback increases the input impedance of an amplifier and parallel-connected current feedback decreases it.

In the amplifier illustrated in Fig. 42 the grid leak  $R_{gl}$  is connected directly across the input terminals. Thus the resistive component of the input impedance is  $R_{gl}$  and is not affected by changes in the cathode connections of the valve. The input resistance is, therefore, not affected by the application of negative feedback to the amplifier. (The addition of feedback will, however, decrease the inter-electrode capacitive component of the input impedance.)

In Fig. 43, where the grid leak is returned to a tapping point on the cathode resistor, the addition of current feedback to the amplifier does alter the effective input resistance. The effective input impedance is calculated in Appendix 5 and is given by

## NEGATIVE FEEDBACK

$$R_{in} = R_{gl} \left[ \frac{1 + g_m(R_b + R_k)}{1 + g_m R_b} \right] \dots \dots \dots (91)$$

Thus the application of series-connected current feedback increases the input impedance of the amplifier by an amount dependent on the value of  $R_k$ . If  $R_k$  is decreased to zero, the input impedance decreases to  $R_{gl}$  and the circuit of Fig. 43 simplifies to that of Fig. 42.

### 3. Effect on Output Impedance

It is shown in Appendix 5 that the effective anode a.c. resistance  $r_a'$  of the valve in Fig. 43 is given by

$$r_a' = r_a + \mu(R_b + \beta_2 R_k) \dots \dots \dots (92)$$

Thus  $r_a'$  depends on  $R_{gen}$ , the internal resistance of the signal source, particularly if  $R_{gen}$  is large compared with  $R_{gl}$ . If  $R_{gen}$  is small compared with  $R_{gl}$ ,  $\beta_2$  tends to unity and  $r_a'$  to  $r_a + \mu(R_k + R_b)$ . The relationship between output impedance and  $r_a'$  was explained on p. 33. Current feedback is, however, generally used with voltage amplifiers which are not called upon to supply power to external loads and knowledge of the output impedance is thus not often required.

## Parallel-connected Current Feedback. More Detailed Considerations

### 1. Effect on Gain

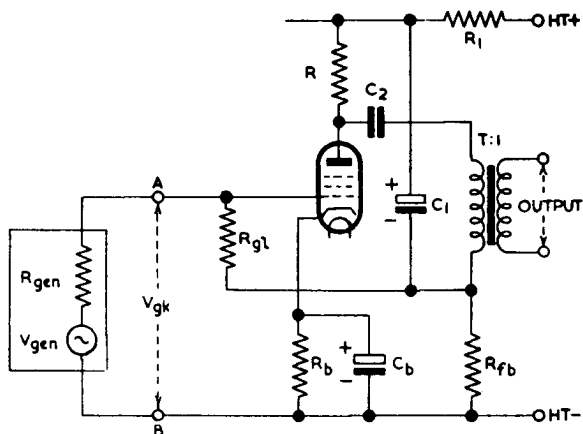

Fig. 44. A circuit providing parallel-connected Current Feedback

Fig. 44 gives the circuit of a single-stage amplifier in which current feedback is obtained from the anode circuit by the method of Fig. 37. The

## NEGATIVE FEEDBACK

feedback voltage developed across  $R_{fb}^*$  is injected into the grid circuit by way of the grid leak  $R_{gl}$  in the same way as in Fig. 26 and is thus an example of parallel-connected current feedback. This is the feedback circuit used in the *AMC/2* amplifier.

$R_{gl}$  and  $R_{gen}$  are connected in series across  $R_{fb}$  and form a potential divider in the feedback circuit since only the voltage appearing across  $R_{gen}$  is applied between grid and cathode. Thus the amount of feedback and the performance of the amplifier is dependent on the value of the source resistance.

From Appendix 6 :—

$$V_{fb} = \beta V_{out} = \beta_1(1 - \beta_2) V_{out} \quad \dots \quad \dots \quad (93)$$

where 
$$\beta_1 = \frac{R_{fb}}{R_l},$$

and 
$$\beta_2 = \frac{R_{gl}}{R_{gl} + R_{gen}}$$

where  $R_l$  is the effective anode load of the valve i.e.,  $R$  and the reflected load at the primary of the output transformer in parallel.  $V_{out}$  is the signal p.d. at the anode of the valve. The reactance of  $C_2$  is assumed negligible.

Since the input terminals of the amplifier are virtually connected directly to the grid and cathode of the valve, the gain of the amplifier between *input terminals* and *valve anode* (i.e.  $V_{out}/V_{in} = V_{out}/V_{gk}$ ) is given by  $g_m R_l$  whether feedback is applied or not. Measured in this way the voltage gain is thus independent of the source resistance and in order to calculate the reduction in gain due to the feedback, the gain should be measured by the expression  $V_{out}/V_{gen}$ .

From Appendix 6 :—

$$\frac{V_{out}}{V_{gen}} = \frac{g_m R_l \beta_2}{1 + g_m R_{fb} (1 - \beta_2)} \quad \dots \quad \dots \quad \dots \quad (94)$$

Thus the gain depends on the resistance  $R_{fb}$  and the ratio of grid leak to the generator resistance of the signal source.

Expression (94) shows that when  $R_{gen}$  is small compared with  $R_{gl}$ ,  $\beta_2$  tends to unity and the gain of the amplifier tends to  $g_m R_l$  the gain from input to valve anode.

When  $R_{gen}$  is large compared with  $R_{gl}$ ,  $\beta_2$  tends to zero and the gain of the amplifier also tends to zero. This is obvious from Fig. 44 ; when  $R_{gen}$  is large compared with  $R_{gl}$ , there is a large loss due to the potential divider formed by  $R_{gen}$  and  $R_{gl}$  and the output tends to zero.

---

\* The effective feedback resistance is that of  $R_{fb}$  and  $R_l$  in parallel. See p. 66.

## NEGATIVE FEEDBACK

### 2. Effect on Input Impedance

If  $R_{fb}$  is made zero in Fig. 44 there is no feedback and the input resistance of the amplifier is clearly  $R_{gl}$  since this component is connected directly across the input terminals. Because the cathode of the valve is effectively earthed at audio-frequencies, the input terminals are virtually connected between grid and cathode. Thus  $V_{in} = V_{gk}$  and the current in  $R_{gl}$  is  $V_{gk}/R_{gl}$  for an input signal  $V_{gk}$ .

Let the input signal be  $V_{gk}$  when feedback is applied. The p.d. across  $R_{gl}$  is made up of  $V_{gk}$  volts at the end connected to the grid and  $IR_{fb}$  ( $= g_m V_{gk} R_{fb}$ ) volts at the other end. These two voltages are additive and the total e.m.f. across  $R_{gl}$  is  $V_{gk}(1 + g_m R_{fb})$ .

$$\therefore \text{Current in } R_{gl} = \frac{V_{gk}(1 + g_m R_{fb})}{R_{gl}}$$

But the input signal to the amplifier is  $V_{gk}$

$$\text{input impedance} = \frac{\text{input voltage}}{\text{input current}}$$

$$\begin{aligned} \therefore R_{in} &= \frac{V_{gk}}{\frac{V_{gk}(1 + g_m R_{fb})}{R_{gl}}} \\ &= \frac{R_{gl}}{1 + g_m R_{fb}} \quad \dots \quad \dots \quad \dots \quad (95) \end{aligned}$$

Thus the input resistance is reduced in the ratio  $(1 + g_m R_{fb}) : 1$  by the application of parallel-connected current feedback.

### 3. Effect on Output Impedance

From Appendix 6:—

$$r_a' = r_a + \mu(1 - \beta_2)R_{fb} \quad \dots \quad \dots \quad \dots \quad (96)$$

Thus  $r_a'$  depends on  $\beta_2$  and hence on  $R_{gen}$ . The variation of  $r_a'$  with  $R_{gen}$  is most marked when  $R_{gen}$  is small compared with  $R_{gl}$  and  $\beta_2$  approaches unity. When  $R_{gen}$  is large compared with  $R_{gl}$ ,  $\beta_2$  tends to zero and  $r_a'$  to  $(r_a + \mu R_{fb})$ .

The output impedance of the amplifier of Fig. 44 depends on  $r_a'$ ,  $R$  and the ratio of the transformer according to the formula

$$\text{output impedance} = \frac{1}{T^2} \cdot \frac{r_a' R}{r_a' + R} \quad \dots \quad \dots \quad \dots \quad (97)$$

in which it is assumed that the output transformer has a step-down turns ratio of  $T : 1$ .

## NEGATIVE FEEDBACK

### Some Practical Current Feedback Circuits and Worked Examples

1. Fig. 45 shows a simple amplifier with current feedback. It consists of a pentode valve with a bias resistor  $R_k$  which is not bypassed. For sake of simplicity the connections to screen and suppressor grids are omitted.

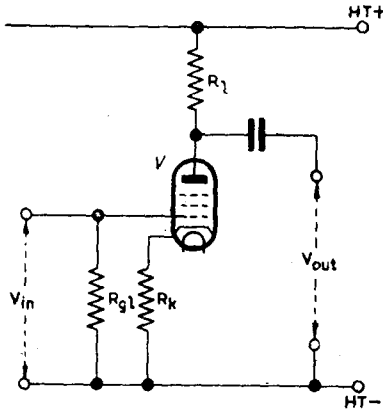

Fig. 45. Basic Circuit of an Amplifier with Current Feedback

Let

$r_a$	=	1 Megohm
$g_m$	=	2 mA/Volt
$R_l$	=	100,000 ohms
$R_k$	=	2,000 ohms.

It is required to find :

- (a) the gain of the valve, from input terminals to anode,
  - (b) the effective anode a.c. resistance of the valve.
- (a) The gain of the valve from grid-cathode to anode is given by

$$\begin{aligned}
 A &\simeq g_m R_l \\
 &= \frac{2}{1,000} \times 100,000 \\
 &= 200
 \end{aligned}$$

The value of  $\beta$  is given approximately by  $R_k/R_l$

$$\therefore \beta \simeq \frac{2,000}{100,000} = \frac{1}{50}$$

The gain  $A'$  of the valve from input terminals to anode is given by

$$A' = \frac{A}{1 + A\beta}$$

## NEGATIVE FEEDBACK

$$\begin{aligned}
 &= \frac{200}{1 + 200 \times \frac{1}{50}} \\
 &= \frac{200}{5} \\
 &= 40
 \end{aligned}$$

An alternative method of calculating  $A'$  is directly from the formula

$$\begin{aligned}
 A' &= \frac{g_m R_l}{1 + g_m R_k} \quad * \\
 &= \frac{\frac{2}{1,000} \times 100,000}{1 + \frac{2}{1,000} \times 2,000} \\
 &= \frac{200}{5} \\
 &= 40
 \end{aligned}$$

(b) The effective value of anode a.c. resistance is given by

$$r_a' = r_a + (\mu + 1)R_k$$

and thus  $\mu$  must be determined before  $r_a'$  can be calculated.

$$\begin{aligned}
 \mu &= g_m r_a \\
 &= \frac{2}{1,000} \times 1,000,000 \\
 &= 2,000
 \end{aligned}$$

The effective anode a.c. resistance is thus given by

$$\begin{aligned}
 r_a' &= 1,000,000 + 2,000 \times 2,000 \\
 &= 5,000,000 \text{ ohms}
 \end{aligned}$$

2. An amplifier is to be constructed to the circuit of Fig. 46. The characteristics are as follows:—

---

\* But see page 70.

## NEGATIVE FEEDBACK

$$\begin{aligned} r_a &= 1,000,000 \text{ ohms} \\ \mu &= 2,000 \\ g_m &= 2\text{mA/V} \end{aligned}$$

The amplifier is required to have 16 db of current feedback and the valve is to consume an anode current of 2 milliamps with an anode load of 100,000 ohms and a grid bias of 1.5 volts. Find the values of  $R_b$  and  $R_k$ .

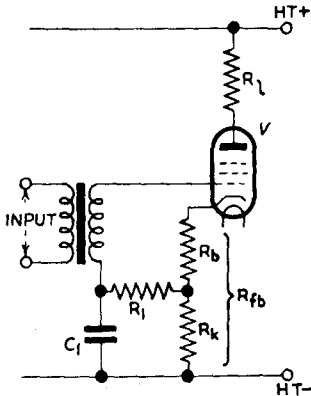

Fig. 46. An Amplifier with Current Feedback

The application of current feedback to an amplifier reduces the voltage gain in the ratio  $(1 + g_m R_{fb}) : 1$ .<sup>\*</sup> This may be expressed in decibels thus:—

$$\text{Number of db of current feedback} = 20 \log_{10}(1 + g_m R_{fb})$$

$$\therefore 20 \log_{10}(1 + g_m R_{fb}) = 16$$

From which, approximately,

$$1 + g_m R_{fb} = 6$$

$$\therefore R_{fb} = \frac{5}{g_m}$$

Putting  $g_m = 2\text{mA/V}$

$$\begin{aligned} R_{fb} &= \frac{5}{\frac{2}{1,000}} \\ &= 2,500 \text{ ohms} \end{aligned}$$

The value of  $R_b$  is given by

$$\begin{aligned} R_b &= \frac{\text{grid bias}}{\text{anode current}} \\ &= \frac{1.5}{\frac{2}{1,000}} \\ &= 750 \text{ ohms} \end{aligned}$$

In Fig. 46  $R_{fb} = R_k + R_b = 2,500$  ohms

and  $R_b = 750$  ohms

$\therefore R_k = 1,750$  ohms

<sup>\*</sup>But see page 70.

## NEGATIVE FEEDBACK

### COMBINED VOLTAGE AND CURRENT FEEDBACK

#### General Considerations

Current and voltage feedback can be combined to give considerable reduction in distortion and at the same time to provide a wanted value of output impedance.

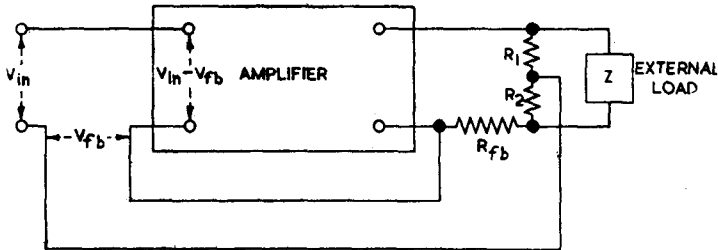

Fig. 47. Basic Circuit for Combined Voltage and Current Feedback

The basic circuit for obtaining combined voltage and current feedback is given in Fig. 47.  $R_{fb}$  provides current feedback and the potential divider  $R_1R_2$  voltage feedback. The equivalent circuit of the final valve of the amplifier can be redrawn as shown in Fig. 48, which has the form of a Wheatstone-bridge circuit. For this reason combined voltage and current feedback is sometimes referred to as *bridge feedback*.

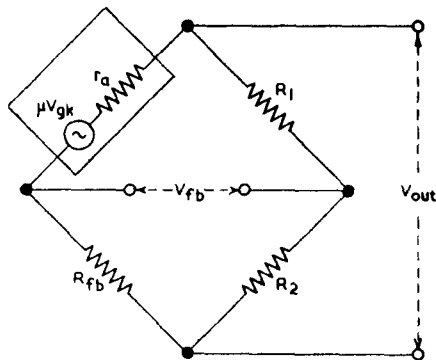

Fig. 48. Equivalent Circuit of Final Valve in Fig. 47

Bridge feedback may be series- or parallel-connected; Fig. 47 shows the connections giving series-connected feedback and this is the only type discussed below.

The derivation of expressions for the gain and effective  $r_a$  of the output valve may be made by methods similar to those used earlier, and is given on the following two pages.



## NEGATIVE FEEDBACK

### Effect of Bridge Feedback on Gain

Let the amplifier of Fig. 47 contain a single valve. Then

$$I = \frac{\mu(V_{in} - V_{fb})}{r_a + Z + R_{fb}} \quad \dots \quad \dots \quad \dots \quad (98)$$

and  $V_{fb} = IR_{fb} + \beta_v IZ \dots \dots \dots (99)$

in which  $\beta_v =$  voltage feedback factor  $= \frac{R_2}{R_1 + R_2}$

Substituting for  $V_{fb}$  from (99) in (98)

$$I = \frac{\mu(V_{in} - IR_{fb} - \beta_v IZ)}{r_a + Z + R_{fb}}$$

Solving for  $I$

$$I = \frac{\mu V_{in}}{r_a + Z(1 + \mu\beta_v) + R_{fb}(1 + \mu)} \quad \dots \quad \dots \quad (100)$$

Now  $V_{out} = IZ$

$$\therefore \frac{V_{out}}{V_{in}} = A' = \frac{\mu Z}{r_a + Z(1 + \mu\beta_v) + R_{fb}(1 + \mu)}$$

Dividing numerator and denominator by  $r_a + Z$

$$A' = \frac{\frac{\mu Z}{r_a + Z}}{1 + \frac{\mu Z \beta_v}{r_a + Z} + \frac{\mu Z}{r_a + Z} \cdot \frac{1 + \mu}{\mu} \cdot \frac{R_{fb}}{Z}}$$

In this expression  $\mu Z/(r_a + Z)$  is the gain,  $A$ , from grid-cathode to anode.  $(1 + \mu)$  may be taken as  $\mu$  with little error, as  $\mu$  is usually large compared with unity.  $R_{fb}/Z$  may be written as  $\beta_i$ , the fraction of the amplifier output which is fed back as current feedback. Thus

$$\begin{aligned} A' &= \frac{A}{1 + A\beta_v + A\beta_i} \\ &= \frac{A}{1 + A(\beta_v + \beta_i)} \quad \dots \quad \dots \quad (101) \end{aligned}$$

Thus the voltage and current feedback may be considered separately and the corresponding values of  $\beta$  may be added in determining the gain of the amplifier.

If  $Z$  is small compared with  $r_a$ ,  $A \simeq g_m Z$  and (101) may be written

## NEGATIVE FEEDBACK

$$\begin{aligned}
 A' &= \frac{A}{1 + A\beta_v + g_m Z \cdot \frac{R_{fb}}{Z}} \\
 &= \frac{A}{1 + A\beta_v + g_m R_{fb}} \quad \dots \quad \dots \quad (102)
 \end{aligned}$$

### Effect of Bridge Feedback on Output Impedance

Dividing the numerator and denominator of (100) by  $(1 + \mu\beta_v)$

$$I = \frac{\frac{\mu V_{in}}{1 + \mu\beta_v}}{Z + \frac{r_a + (1 + \mu)R_{fb}}{1 + \mu\beta_v}} \quad \dots \quad \dots \quad (103)$$

From this it is clear that the amplification factor is in effect reduced to  $\mu/(1 + \mu\beta_v)$ .

$$\therefore \mu' = \frac{\mu}{1 + \mu\beta_v}$$

The effective value of the anode a.c. resistance is changed to

$$r_a' = \frac{r_a + (1 + \mu)R_{fb}}{1 + \mu\beta_v} \quad \dots \quad \dots \quad \dots \quad (104)$$

The effect of current feedback can be seen in the numerator of expression (104) (which has the same form as expression 84) and the effect of voltage feedback can be seen in the denominator.

If  $\mu\beta_v$  is large compared with unity, expression (104) can be restated

$$r_a' = \frac{r_a + (1 + \mu)R_{fb}}{\mu\beta_v}$$

and if  $(1 + \mu)/\mu$  is taken as unity

$$r_a' \cong \frac{1}{\beta_v} \left( \frac{1}{g_m} + R_{fb} \right) \quad \dots \quad \dots \quad \dots \quad (105)$$

This expression shows that  $r_a'$  can be increased by increasing  $R_{fb}$  and decreased by increasing  $\beta_v$ . It also shows that  $R_{fb}$  must be comparable with or greater than  $1/g_m$  to have an appreciable effect on  $r_a'$ .

The relationship between output impedance and  $r_a'$  has been dealt with under voltage and current feedback and reference should be made to these sections for information on this topic.

APPENDIX

APPENDIX 1

SERIES-CONNECTED VOLTAGE NEGATIVE FEEDBACK

The essential features of Fig. 25 are reproduced in Fig. 1.1. The current  $I_{gen}$  in the circuit is given by

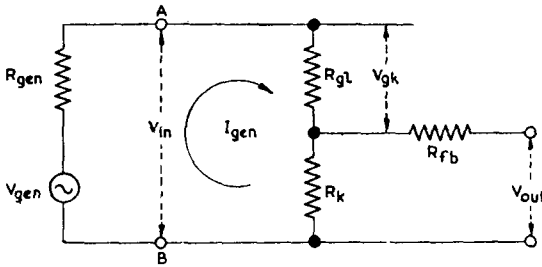

$$I_{gen} = \frac{V_{gen} - V_{Rk}}{R_{gen} + R_{gl} + R_k}$$

But  $R_k$  is small compared with  $R_{gen}$  and  $R_{gl}$  and may be neglected in comparison with them.  $V_{Rk}$  is equal to  $\beta_1 V_{out}$  where  $\beta_1 = R_k / (R_k + R_{fb})$ . Neglecting  $R_k$  and substituting for  $\beta_1$ .

Fig. 1.1. Equivalent Circuit of Fig. 25

$$I_{gen} = \frac{V_{gen} - \beta_1 V_{out}}{R_{gen} + R_{gl}} \dots \dots \dots (1)$$

$$\begin{aligned} V_{gk} &= I_{gen} R_{gl} \\ &= \frac{R_{gl}}{R_{gen} + R_{gl}} \cdot (V_{gen} - \beta_1 V_{out}) \\ &= \beta_2 (V_{gen} - \beta_1 V_{out}) \dots \dots \dots (2) \end{aligned}$$

where  $\beta_2 = R_{gl} / (R_{gl} + R_{gen})$

The a.c. component of anode current is given by the usual expression

$$I = \frac{\mu V_{gk}}{r_a + R_l}$$

where  $R_l$  is the effective anode load of the valve, i.e., the resistance reflected into the primary winding of the output transformer. Substituting for  $V_{gk}$  from (2)

$$I = \frac{\mu \beta_2 (V_{gen} - \beta_1 V_{out})}{r_a + R_l} \dots \dots \dots (3)$$

Now  $\beta_1 V_{out} = \beta_1 \beta_3 I R_l$  and  $\beta_3 = I/T$  where  $T : 1$  is the step-down turns ratio of the output transformer. See Fig. 25.

Substituting for  $\beta_1 V_{out}$  in (3)

$$I = \frac{\mu \beta_2 (V_{gen} - \beta_1 \beta_3 I R_l)}{r_a + R_l}$$

## APPENDIX

Solving for  $I$

$$I = \frac{\mu \beta_2 V_{gen}}{r_a + R_l + \mu \beta_1 \beta_2 \beta_3 R_l} \dots \dots \dots (4)$$

**Determination of Gain with respect to  $V_{gen}$**

$$V_{out} = I \beta_3 R_l$$

Substituting for  $I$  from (4) and re-arranging

$$\frac{V_{out}}{V_{gen}} = \frac{\mu \beta_2 \beta_3 R_l}{r_a + R_l + \mu \beta_1 \beta_2 \beta_3 R_l} \dots \dots \dots (5)$$

Dividing numerator and denominator by  $(r_a + R_l)$

$$\frac{V_{out}}{V_{gen}} = \frac{\frac{\mu \beta_2 \beta_3 R_l}{r_a + R_l}}{1 + \frac{\mu \beta_1 \beta_2 \beta_3 R_l}{r_a + R_l}} \dots \dots \dots (6)$$

But  $\mu \beta_3 R_l (r_a + R_l) = A$ , the gain from grid-cathode to output terminals

$$\therefore \frac{V_{out}}{V_{gen}} = \frac{A \beta_2}{1 + A \beta_1 \beta_2} \dots \dots \dots (7)$$

As pointed out in the text, this result can be obtained directly from expression (50) by substituting  $A \beta_2$  for  $A$  and  $\beta_1$  for  $\beta$ .

**Determination of Gain with Respect to  $V_{in}$**

$$\begin{aligned} V_{in} &= V_{gk} + \beta_1 V_{out} \\ &= V_{gk} + A \beta_1 V_{gk} \\ &= V_{gk} (1 + A \beta_1) \end{aligned}$$

$$V_{out} = A V_{gk}$$

$$\therefore \frac{V_{out}}{V_{in}} = \frac{A}{1 + A \beta_1}$$

**Determination of Effective Anode A.C. Resistance**

Re-arranging (4)

$$I = \frac{\mu \beta_2 V_{gen}}{r_a + R_l (1 + \mu \beta_1 \beta_2 \beta_3)}$$

Dividing numerator and denominator by  $(1 + \mu \beta_1 \beta_2 \beta_3)$

APPENDIX

$$I = \frac{\frac{\mu \beta_2 V_{gen}}{1 + \mu \beta_1 \beta_2 \beta_3}}{R_l + \frac{r_a}{1 + \mu \beta_1 \beta_2 \beta_3}}$$

Comparing this with the general expression

$$I = \frac{\mu V_{gh}}{R_l + r_a}$$

we see that the effective  $\mu$  is given by

$$\mu' = \frac{\mu \beta_2}{1 + \mu \beta_1 \beta_2 \beta_3} \dots \dots \dots \dots \dots \quad (8)$$

and that the effective  $r_a$  is given by

$$r_a' = \frac{r_a}{1 + \mu \beta_1 \beta_2 \beta_3} \dots \dots \dots \dots \dots \quad (9)$$

Expressions (8) and (9) can be obtained directly from the general expressions  $\mu' = \mu/(1 + \mu\beta)$  and  $r_a' = r_a/(1 + \mu\beta)$  by putting  $\beta = \beta_1\beta_2\beta_3$ .

APPENDIX

APPENDIX 2

Parallel-connected Voltage Negative Feedback

The essential features of Fig. 26 are reproduced in Fig. 2.1. The current,  $I_{gen}$  in the circuit is given by

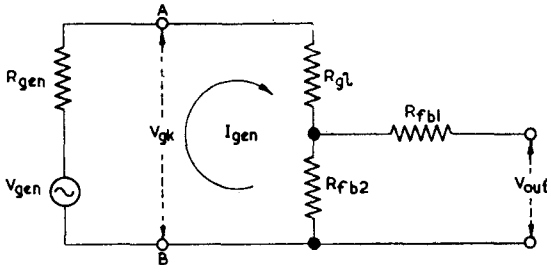

Fig. 2.1. Equivalent Circuit of Fig. 26

$$I_{gen} = \frac{V_{gen} + V_{fb2}}{R_{gen} + R_{gl} + R_{fb2}}$$

But  $R_{fb2}$  is generally small in comparison with  $R_{gen}$  and  $R_{gl}$  and may be neglected in comparison with them

$$\therefore I_{gen} = \frac{V_{gen} + V_{fb2}}{R_{gen} + R_{gl}}$$

From Fig. 2.1

$$V_{fb2} = \frac{R_{fb2}}{R_{fb1} + R_{fb2}} \cdot V_{out} = \beta_1 V_{out}$$

where  $\beta_1 = \frac{R_{fb2}}{R_{fb1} + R_{fb2}}$

Substituting for  $V_{fb2}$

$$I_{gen} = \frac{V_{gen} + \beta_1 V_{out}}{R_{gen} + R_{gl}} \quad \dots \quad \dots \quad \dots \quad \dots \quad (1)$$

$V_{gk}$ , the p.d. across AB, is equal to the p.d. across  $R_{gl}$  less the p.d. across  $R_{fb2}$ . Thus

$$\begin{aligned} V_{gk} &= I_{gen} R_{gl} - V_{fb2} \\ &= I_{gen} R_{gl} - \beta_1 V_{out} \end{aligned}$$

Substituting for  $I_{gen}$  from (1)

$$V_{gk} = \frac{R_{gl}}{R_{gen} + R_{gl}} (V_{gen} + \beta_1 V_{out}) - \beta_1 V_{out}$$

which may be written

$$\begin{aligned} V_{gk} &= \beta_2 V_{gen} + \beta_1 (\beta_2 - 1) V_{out} \quad \dots \quad \dots \quad \dots \quad (2) \\ &= \beta_2 V_{gen} - \beta_1 (1 - \beta_2) V_{out} = \beta_2 V_{gen} - V_{fb} \end{aligned}$$

where  $\beta_2 = \frac{R_{gl}}{R_{gen} + R_{gl}}$

The a.c. component of the anode current,  $I$ , is given by the usual expression

## APPENDIX

$$I = \frac{\mu V_{gh}}{r_a + R_l}$$

Substituting for  $V_{gh}$  from (2)

$$I = \frac{\mu \beta_2 V_{gen} - \mu \beta_1 (1 - \beta_2) V_{out}}{r_a + R_l} \quad \dots \quad \dots \quad (3)$$

Now  $V_{out} = IR_l$ . (See Fig. 26.)

Substituting for  $V_{out}$  in (3)

$$\therefore I = \frac{\mu \beta_2 V_{gen} - \mu \beta_1 (1 - \beta_2) IR_l}{r_a + R_l}$$

Solving for  $I$

$$I = \frac{\mu \beta_2 V_{gen}}{r_a + R_l + \mu \beta_1 (1 - \beta_2) R_l} \quad \dots \quad \dots \quad \dots \quad (4)$$

**Determination of Gain with Respect to  $V_{gen}$**

$$V_{out} = IR_l$$

Substituting for  $I$  from (4) and re-arranging

$$\frac{V_{out}}{V_{gen}} = \frac{\mu \beta_2 R_l}{r_a + R_l + \mu \beta_1 (1 - \beta_2) R_l}$$

Dividing numerator and denominator by  $(r_a + R_l)$

$$\frac{V_{out}}{V_{gen}} = \frac{\frac{\mu \beta_2 R_l}{r_a + R_l}}{1 + \frac{\mu \beta_1 (1 - \beta_2) R_l}{r_a + R_l}}$$

But  $\frac{\mu R_l}{r_a + R_l} = A$ , the gain from input to output terminals

$$\therefore \frac{V_{out}}{V_{gen}} = \frac{A \beta_2}{1 + A \beta_1 (1 - \beta_2)} \quad \dots \quad \dots \quad \dots \quad (5)$$

**Determination of the Effective Anode A.C. Resistance**

Re-arranging (4)

$$I = \frac{\mu \beta_2 V_{gen}}{r_a + R_l [1 + \mu \beta_1 (1 - \beta_2)]}$$

Dividing numerator and denominator by  $1 + \mu \beta_1 (1 - \beta_2)$

APPENDIX

$$I = \frac{\frac{\mu \beta_2 V_{gen}}{1 + \mu \beta_1 (1 - \beta_2)}}{R_l + \frac{r_a}{1 + \mu \beta_1 (1 - \beta_2)}}$$

Comparing this with the general expression

$$I = \frac{\mu I_{gk}}{R_l + r_a}$$

we see that the effective  $\mu$  is given by

$$\mu' = \frac{\mu \beta_2}{1 + \mu \beta_1 (1 - \beta_2)} \dots \dots \dots (6)$$

and that the effective  $r_a$  is given by

$$r_a' = \frac{r_a}{1 + \mu \beta_1 (1 - \beta_2)} \dots \dots \dots (7)$$



APPENDIX

APPENDIX 3

The Cathode Follower

The essential features of Fig. 32 are reproduced in Fig. 3.1. The current in the circuit,  $I_{gen}$ , is given by

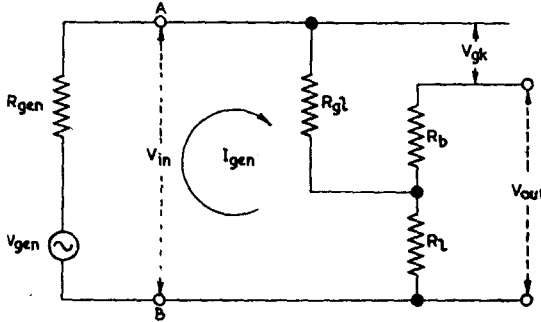

Fig. 3.1. Equivalent Circuit of Fig. 32

$$I_{gen} = \frac{V_{gen} - V_{Rl}}{R_{gen} + R_{gl} + R_l} \quad \dots \quad \dots \quad \dots \quad (1)$$

Normally  $R_l$  is small compared with  $(R_{gen} + R_{gl})$  and may be neglected in comparison with them.

Moreover

$$V_{Rl} = \frac{R_l}{R_b + R_l} \cdot V_{out} = (1 - \beta_1) V_{out} \quad \dots \quad (2)$$

where 
$$\beta_1 = \frac{R_l}{R_b + R_l}$$

Substituting for  $V_{Rl}$  from (2) in (1) and neglecting  $R_l$

$$I_{gen} = \frac{V_{gen} - (1 - \beta_1) V_{out}}{R_{gen} + R_{gl}} \quad \dots \quad \dots \quad \dots \quad (3)$$

The p.d. between grid and cathode is equal to the p.d. produced by  $I_{gen}$  in flowing through  $R_{gl}$  less the p.d. developed across  $R_b$  by the cathode current.

Thus

$$V_{gk} = I_{gen} R_{gl} - \beta_1 V_{out}$$

Substituting for  $I_{gen}$  from (3)

$$V_{gk} = \frac{R_{gl}}{R_{gen} + R_{gl}} [V_{gen} - (1 - \beta_1) V_{out}] - \beta_1 V_{out}$$

## APPENDIX

Let 
$$\beta_2 = \frac{R_{g1}}{R_{gen} + R_{g1}}$$

$\therefore V_{gk} = \beta_2 [V_{gen} - (1 - \beta_1)V_{out}] - \beta_1 V_{out} \quad \dots \quad (4)$

Now the a.c. component of anode current  $I$  is given by the usual expression

$$I = \frac{\mu V_{gk}}{r_a + R_i + R_b}$$

The bias resistor  $R_b$  is generally small compared with  $(r_a + R_i)$  and may be neglected in comparison with them. Thus

$$I = \frac{\mu V_{gk}}{r_a + R_i}$$

Substituting for  $V_{gk}$  from (4)

$$I = \frac{\mu}{r_a + R_i} \left\{ \beta_2 [V_{gen} - (1 - \beta_1)V_{out}] - \beta_1 V_{out} \right\}$$

But 
$$V_{out} = I(R_i + R_b) \simeq IR_i$$

Substituting for  $V_{out}$  and re-arranging

$$I = \frac{\mu \beta_2 V_{gen} - \mu \beta_2 (1 - \beta_1) IR_i - \mu \beta_1 IR_i}{r_a + R_i}$$

Solving for  $I$

$$I = \frac{\mu \beta_2 V_{gen}}{r_a + R_i [1 + \mu \beta_2 (1 - \beta_1) + \mu \beta_1]} \quad \dots \quad (5)$$

### Determination of Gain with Respect to $V_{gen}$

$$V_{out} = I(R_i + R_b) \simeq IR_i \quad \dots \quad \dots \quad \dots \quad (6)$$

Substituting for  $I$  in (6) and re-arranging

$$\frac{V_{out}}{V_{gen}} = \frac{\mu \beta_2 R_i}{r_a + R_i [1 + \mu \beta_2 (1 - \beta_1) + \mu \beta_1]}$$

Dividing numerator and denominator by  $(r_a + R_i)$

$$\frac{V_{out}}{V_{gen}} = \frac{\frac{\mu \beta_2 R_i}{r_a + R_i}}{1 + \frac{\mu R_i [\beta_2 (1 - \beta_1) + \beta_1]}{r_a + R_i}}$$

But  $\frac{\mu R_i}{r_a + R_i} = A$ , the gain of the valve with respect to a signal applied

## APPENDIX

between grid and cathode.

$$\therefore \frac{V_{out}}{V_{gen}} = \frac{A\beta_2}{1 + A[\beta_2(1 - \beta_1) + \beta_1]} \quad \dots \quad (7)$$

### Determination of Gain with Respect to $V_{in}$

The p.d. between A and B is made up of the p.d. between grid and cathode and the p.d. between cathode and h.t. negative.

$$\therefore V_{in} = V_{gk} + V_{out} \quad \dots \quad (8)$$

But  $V_{out} = AV_{gk}$  and hence  $V_{gk} = \frac{V_{out}}{A}$

Substituting for  $V_{gk}$  in (8)

$$V_{in} = \frac{V_{out}}{A} + V_{out}$$

Re-arranging

$$\frac{V_{out}}{V_{in}} = \frac{A}{1 + A} \quad \dots \quad (9)$$

### Determination of Effective Anode A.C. Resistance

Dividing numerator and denominator of (5) by  $[1 + \mu\beta_2(1 - \beta_1) + \mu\beta_1]$

$$I = \frac{\frac{\mu\beta_2 V_{gen}}{1 + \mu\beta_2(1 - \beta_1) + \mu\beta_1}}{R_l + \frac{r_a}{1 + \mu\beta_2(1 - \beta_1) + \mu\beta_1}}$$

Comparing this with the usual expression

$$I = \frac{\mu V_{gk}}{R_l + r_a}$$

it is clear that the effective amplification factor,  $\mu'$ , is given by

$$\mu' = \frac{\mu\beta_2}{1 + \mu\beta_2(1 - \beta_1) + \mu\beta_1} \quad \dots \quad (10)$$

and that the effective anode a.c. resistance,  $r_a'$  is given by

$$r_a' = \frac{r_a}{1 + \mu\beta_2(1 - \beta_1) + \mu\beta_1} \quad \dots \quad (11)$$

### Determination of Input Impedance

The p.d. across  $R_{gl}$  in Fig. 3.1, is equal to the sum of the p.d. between grid and cathode and the p.d. across  $R_b$ .

## APPENDIX

$$\begin{aligned} \therefore \text{ p.d. across } R_{gl} &= V_{gk} + \beta_1 V_{out} \\ &= V_{gk} + \beta_1 A V_{gk} \end{aligned}$$

Thus the current in  $R_{gl}$ , which is also the current through the input terminals, AB, is given by

$$I_{in} = \frac{V_{gk} + A\beta_1 V_{gk}}{R_{ge}} \quad \dots \quad \dots \quad \dots \quad (12)$$

Now 
$$\begin{aligned} V_{in} &= V_{gk} + V_{out} \\ &= V_{gk} + A V_{gk} \end{aligned}$$

$$\begin{aligned} \therefore \text{ input impedance} &= \frac{V_{in}}{I_{in}} = \frac{V_{gk} + A V_{gk}}{\frac{V_{gk} + A\beta_1 V_{gk}}{R_{gl}}} \\ &= \frac{1 + A}{1 + A\beta_1} R_{gl} \quad \dots \quad \dots \quad \dots \quad (13) \end{aligned}$$

## APPENDIX

### APPENDIX 4

#### Gain of an RC-coupled Triode in Terms of Anode and Bias Resistors Equation to $I_a - V_a$ Characteristics

Fig. 4.1 illustrates the  $I_a - V_a$  curves of an ideal triode: they are straight, parallel and (for equal increments in grid potential) equidistant.

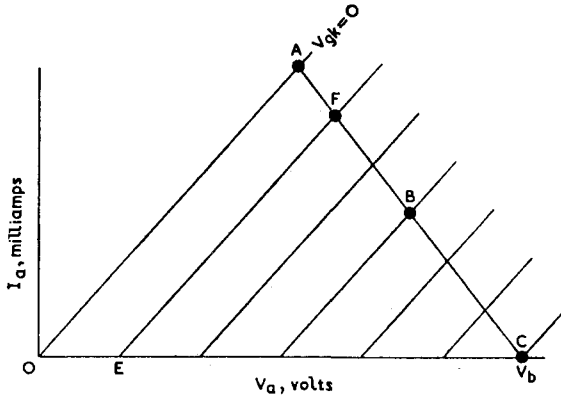

Fig. 4.1. Load Line super-imposed on a Set of Idealised  $I_a - V_a$  Characteristics

The equation to the characteristic passing through the origin, and for which  $V_{gk} = 0$ , is

$$I_a = \frac{V_a}{r_a} \quad \dots \quad \dots \quad \dots \quad \dots \quad (1)$$

where  $r_a$  is the anode a.c. resistance of the valve. Let EF be the  $I_a - V_a$  characteristic for a grid potential of  $-V_{gk}$  volts. The equation to EF is

$$I_a = \frac{V_a}{r_a} + a \quad \dots \quad \dots \quad \dots \quad (2)$$

in which  $a$  is a constant.

The change in anode current brought about by a change in grid potential of  $-V_{gk}$  volts is equal to that brought about by a change in anode potential of  $-\mu V_{gk}$  volts. Thus  $OE = -\mu V_{gk}$  and equation (2) must satisfy the condition that  $I_a = 0$  when  $V_a = -\mu V_{gk}$

$$\therefore 0 = \frac{-\mu V_{gk}}{r_a} + a$$

$$\therefore a = \frac{\mu V_{gk}}{r_a}$$

## APPENDIX

The equation to EF is thus

$$I_a = \frac{V_a + \mu V_{gk}}{r_a} \quad \dots \quad \dots \quad \dots \quad (3)$$

### Equation to the Load Line

AC is the load line for a direct-coupled resistive load of value  $R_l$ . It intersects the  $V_a$  axis where  $V_a = V_b$ , the value of the h.t. supply voltage. The slope of AC is  $-1/R_l$  and its equation is

$$I_a = \frac{-V_a}{R_l} + b$$

where  $b$  is a constant.

But  $I_a = 0$  when  $V_a = V_b$ .

$$\therefore 0 = \frac{-V_b}{R_l} + b$$

$$\therefore b = \frac{V_b}{R_l}$$

The equation to the load line is thus

$$I_a = \frac{V_b - V_a}{R_l} \quad \dots \quad \dots \quad \dots \quad (4)$$

The co-ordinates of point A, where the characteristic for  $V_{gk} = 0$  meets the load line, are obtained by solving (1) and (4) as simultaneous equations. The co-ordinates are :

$$\left. \begin{aligned} I_a &= \frac{V_b}{r_a + R_l} \\ V_a &= \frac{V_b r_a}{r_a + R_l} \end{aligned} \right\} \quad \dots \quad \dots \quad \dots \quad (5)$$

As the valve characteristics are perfect the anode potential may be swung between the limits  $V_b$  and  $\frac{V_b r_a}{r_a + R_l}$  without incurring distortion, and the quiescent point will be at B the centre of AC. The co-ordinates of B are :

$$\left. \begin{aligned} I_a &= \frac{V_b}{2(r_a + R_l)} \\ V_a &= \frac{V_b(2r_a + R_l)}{2(r_a + R_l)} \end{aligned} \right\} \quad \dots \quad \dots \quad \dots \quad (6)$$

These two expressions give the quiescent values of the anode current and anode potential respectively.

## APPENDIX

### Optimum Value of Automatic Bias Resistor

The value of  $V_{gk}$  at B is one half that at C, and the value at C can be obtained by substituting the co-ordinates of C namely  $(V_b, 0)$  in (3)

$$0 = \frac{V_b + \mu V_{gk}}{r_a}$$

$$\therefore V_{gk} = \frac{-V_b}{\mu}$$

The value of  $V_{gk}$  at B is hence  $\frac{-V_b}{2\mu}$  and the automatic bias resistor  $R_b$  is given by  $V_{gk}/I_a$ , i.e.,

$$R_b = \frac{V_{gk}}{I_a} = \frac{V_b}{2\mu} \cdot \frac{2(r_a + R_l)}{V_b}$$

$$= \frac{r_a + R_l}{\mu} = \frac{1 + R_l/r_a}{g_m} \dots \dots \dots (7)$$

The expression shows that the value of the grid bias resistor is dependent only on the ratio of  $R_l$  to  $r_a$  and on the mutual conductance of the valve.

### Stage Gain

When the valve delivers maximum undistorted output the anode potential swings between  $V_b$  and  $\frac{V_b r_a}{r_a + R_l}$  (See Fig. 4.1 and expression (5)) : to provide such an output the grid potential must swing between  $\frac{-V_b}{\mu}$  and 0 respectively. Thus the stage gain is given by

$$A = \frac{V_b - \frac{V_b r_a}{r_a + R_l}}{\frac{-V_b}{\mu}}$$

$$= \frac{\mu R_l}{r_a + R_l} \dots \dots \dots (8)$$

### Gain Expressed in Terms of $R_l$ and $R_b$

From (7)

$$R_b = \frac{r_a + R_l}{\mu}$$

APPENDIX

$$= \frac{r_a + R_l}{\mu R_l} \cdot R_l$$

But from (8)

$$\frac{r_a + R_l}{\mu R_l} = \frac{1}{A}$$

$$\therefore R_b = \frac{R_l}{A}$$

$$\therefore A = \frac{R_l}{R_b} \quad \dots \quad \dots \quad \dots \quad \dots \quad (9)$$

Thus the gain of an RC-coupled stage, from grid-cathode to anode, is equal to the anode-load resistor divided by the optimum value of bias resistor. This result was evaluated for an ideal valve and practical circuits satisfy the expression only approximately.



APPENDIX 5

Series-connected Current Negative Feedback

The essential features of Fig. 43 are reproduced in Fig. 5.1. The current

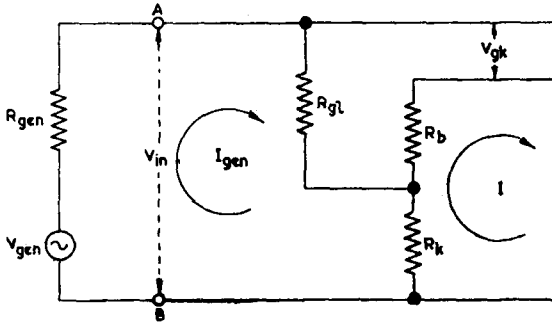

Fig. 5.1. Equivalent Circuit of Fig. 43

$I_{gen}$  in the circuit is given by

$$I_{gen} = \frac{V_{gen} - IR_k}{R_{gen} + R_{gl} + R_k}$$

where  $I$  is the a.c. component of the anode current of the valve. Normally  $R_k$  is very small in comparison with  $R_{gen}$  and  $R_{gl}$  and may be neglected.

Thus we have

$$I_{gen} = \frac{V_{gen} - IR_k}{R_{gen} + R_{gl}} \dots \dots \dots (1)$$

The grid-cathode signal of the valve is given by the p.d. developed by  $I_{gen}$  in flowing through  $R_{gl}$  less the p.d. developed by  $I$  in flowing through  $R_b$ .

Thus

$$V_{gk} = I_{gen} R_{gl} - IR_b \dots \dots \dots (2)$$

Substituting for  $I_{gen}$  in (2) from (1)

$$\begin{aligned} V_{gk} &= \frac{R_{gl}}{R_{gen} + R_{gl}} (V_{gen} - IR_k) - IR_b \\ &= \beta_2 V_{gen} - \beta_2 IR_k - IR_b \dots \dots \dots (3) \end{aligned}$$

where  $\beta_2 = R_{gl}/(R_{gen} + R_{gl})$ .

The anode current of the valve is given by the usual expression

$$I = \frac{\mu V_{gk}}{r_a + R_l}$$

in which  $R_k$  and  $R_b$  are neglected in comparison with  $r_a$  and  $R_l$ . Substituting for  $V_{gk}$  from (3)

$$I = \frac{\mu \beta_2 V_{gen} - \mu \beta_2 IR_k - \mu IR_b}{r_a + R_l}$$

Solving for  $I$

$$I = \frac{\mu \beta_2 V_{gen}}{r_a + R_l + \mu \beta_2 R_k + \mu R_b} \dots \dots (4)$$

## APPENDIX

### Determination of Gain with Respect to $V_{gen}$

$$V_{out} = IR_l$$

Substituting for  $I$  from (4) and re-arranging

$$\frac{V_{out}}{V_{gen}} = \frac{\mu \beta_2 R_l}{r_a + R_l + \mu \beta_2 R_k + \mu R_b} \quad \dots \quad (5)$$

Dividing numerator and denominator by  $(r_a + R_l)$

$$\frac{V_{out}}{V_{gen}} = \frac{\frac{\mu \beta_2 R_l}{r_a + R_l}}{1 + \frac{\mu \beta_2 R_k}{r_a + R_l} + \frac{\mu R_b}{r_a + R_l}} \quad \dots \quad (6)$$

But  $\mu R_l / (r_a + R_l) = A$ , the gain of the valve with respect to signals applied between grid and cathode.

$$\therefore \frac{V_{out}}{V_{gen}} = \frac{A \beta_2}{1 + A \beta_2 \frac{R_k}{R_l} + A \cdot \frac{R_b}{R_l}} \quad \dots \quad (7)$$

Putting  $A = g_m R_l$

$$\frac{V_{out}}{V_{gen}} = \frac{g_m R_l \beta_2}{1 + g_m (R_b + \beta_2 R_k)}$$

### Determination of Gain with Respect to $V_{in}$

From Fig. 5.1.

$$\begin{aligned} V_{in} &= V_{gk} + I(R_b + R_k) \\ &= V_{gk} + \frac{\mu V_{gk}(R_b + R_k)}{r_a + R_l} \\ &= V_{gk} (1 + A \beta_1) \quad \dots \quad \dots \quad \dots \quad (8) \end{aligned}$$

where  $\beta_1 = (R_b + R_k) / R_l$

$$\begin{aligned} \frac{V_{out}}{V_{in}} &= \frac{A V_{gk}}{V_{gk} (1 + A \beta_1)} \\ &= \frac{A}{1 + A \beta_1} \\ &= \frac{g_m R_l}{1 + g_m (R_b + R_k)} \quad \dots \quad \dots \quad \dots \quad (9) \end{aligned}$$

### Determination of Effective Anode A.C. Resistance

Comparison between (4) and the usual expression for valve-anode current

## APPENDIX

$$I = \frac{\mu V_{gk}}{r_a + R_l}$$

shows that the effective amplification factor,  $\mu'$ , in the presence of feedback is given by

$$\mu' = \mu \beta_2$$

and that the effective anode a.c. resistance,  $r_a'$  is given by

$$\begin{aligned} r_a' &= r_a + \mu \beta_2 R_k + \mu R_b \\ &= r_a + \mu(R_b + \beta_2 R_k) \quad \dots \quad \dots \quad \dots \quad (10) \end{aligned}$$

### Determination of Effective Input Impedance

The p.d. across  $R_{gl}$  is made up of  $V_{gk}$  and the p.d. developed by  $I$  in flowing through  $R_b$ .

$$\therefore \text{current in } R_{gl} = \frac{V_{gk} + IR_b}{R_{gl}}$$

$$\text{But } IR_b = \frac{\mu V_{gk}}{r_a + R_l} \cdot R_b = V_{gk} \cdot \frac{\mu R_l}{r_a + R_l} \cdot \frac{R_b}{R_l} = V_{gk} \cdot A \cdot \frac{R_b}{R_l}$$

$$\therefore \text{current in } R_{gl} = \frac{V_{gk} \left( 1 + A \cdot \frac{R_b}{R_l} \right)}{R_{gl}}$$

$V_{in}$  is made up of  $V_{gk}$  and the p.d. developed by  $I$  in flowing through  $R_b$  and  $R_k$

$$\therefore V_{in} = V_{gk} + I(R_b + R_k)$$

$$\begin{aligned} \text{But } I(R_b + R_k) &= \frac{\mu V_{gk}}{r_a + R_l} \cdot (R_b + R_k) = V_{gk} \left( \frac{\mu R_l}{r_a + R_l} \right) \frac{R_b + R_k}{R_l} \\ &= V_{gk} A \beta_1 \end{aligned}$$

$$\therefore V_{in} = V_{gk} (1 + A \beta_1)$$

$$\begin{aligned} \text{Input impedance} &= \frac{V_{in}}{\text{current in } R_{gl}} \\ &= \frac{V_{gk} (1 + A \beta_1)}{V_{gk} \left( 1 + A \cdot \frac{R_b}{R_l} \right)} \\ &\quad R_{gl} \end{aligned}$$

APPENDIX

$$\begin{aligned} &= R_{gl} \left[ \frac{1 + A \beta_1}{1 + A \cdot \left(\frac{R_b}{R_l}\right)} \right] \\ &= R_{gl} \left[ \frac{1 + g_m (R_b + R_k)}{1 + g_m R_b} \right] \dots \dots \dots (11) \end{aligned}$$

## APPENDIX

### APPENDIX 6

#### Parallel-connected Current Negative Feedback

The essential features of Fig. 44 are reproduced in Fig. 6.1. The current  $I_{gen}$ , in the circuit is given by

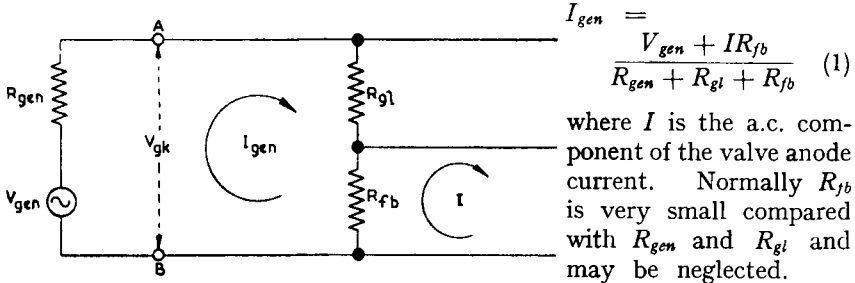

$$I_{gen} = \frac{V_{gen} + IR_{fb}}{R_{gen} + R_{gl} + R_{fb}} \quad (1)$$

where  $I$  is the a.c. component of the valve anode current. Normally  $R_{fb}$  is very small compared with  $R_{gen}$  and  $R_{gl}$  and may be neglected. Equation (1) may thus be written in the form

Fig. 6.1. Equivalent Circuit of Fig. 44.

$$I_{gen} = \frac{V_{gen} + IR_{fb}}{R_{gen} + R_{gl}} \quad \dots \quad \dots \quad \dots \quad (2)$$

$V_{gk}$  is made up of the p.d. across  $R_{gl}$  and the p.d. across  $R_{fb}$

$$\therefore V_{gk} = I_{gen} R_{gl} - IR_{fb} \quad \dots \quad \dots \quad \dots \quad (3)$$

Substituting for  $I_{gen}$  from (2) in (3)

$$V_{gk} = \frac{R_{gl}}{R_{gen} + R_{gl}} (V_{gen} + IR_{fb}) - IR_{fb}$$

$$\therefore V_{gk} = \beta_2 V_{gen} - (1 - \beta_2) IR_{fb} \quad \dots \quad \dots \quad \dots \quad (4)$$

where  $\beta_2 = \frac{R_{gl}}{R_{gen} + R_{gl}}$

The anode current  $I$  is given by the usual expression

$$I = \frac{\mu V_{gk}}{r_a + R_l}$$

in which  $R_{fb}$  is neglected in comparison with  $R_l$  and  $r_a$ . Substituting for  $V_{gk}$  from (4)

$$I = \frac{\mu \beta_2 V_{gen} - \mu(1 - \beta_2) IR_{fb}}{r_a + R_l}$$

Solving for  $I$

$$I = \frac{\mu \beta_2 V_{gen}}{r_a + R_l + \mu(1 - \beta_2) R_{fb}} \quad \dots \quad \dots \quad \dots \quad (5)$$

## APPENDIX

### Determination of Gain with Respect to $V_{gen}$

$$V_{out} = IR_l$$

Substituting for  $I$  from (5) and re-arranging

$$\frac{V_{out}}{V_{gen}} = \frac{\mu \beta_2 R_l}{r_a + R_l + \mu(1 - \beta_2)R_{fb}}$$

Dividing numerator and denominator by  $r_a + R_l$

$$\frac{V_{out}}{V_{gen}} = \frac{\frac{\mu \beta_2 R_l}{r_a + R_l}}{1 + \frac{\mu(1 - \beta_2)R_{fb}}{r_a + R_l}}$$

But  $\mu R_l / (r_a + R_l) = A$ , the gain with respect to a signal applied between grid and cathode

$$\therefore \frac{V_{out}}{V_{gen}} = \frac{A \beta_2}{1 + A(1 - \beta_2)} \cdot \frac{R_{fb}}{R_l}$$

If  $R_{fb}/R_l = \beta_1$  this may be written

$$\frac{V_{out}}{V_{gen}} = \frac{A \beta_2}{1 + A \beta_1 (1 - \beta_2)}$$

If  $A = g_m R_l$

$$\frac{V_{out}}{V_{gen}} = \frac{g_m R_l \beta_2}{1 + g_m R_{fb} (1 - \beta_2)} \quad \dots \quad \dots \quad \dots \quad (6)$$

### Determination of the Effective Anode A.C. Resistance

Comparison of expression (5) with the general expression for anode current

$$\frac{\mu V_{gk}}{r_a + R_l}$$

shows that the effective  $\mu$  is given by

$$\mu' = \mu \beta_2$$

and that the effective  $r_a$  is given by

$$r_a' = r_a + \mu(1 - \beta_2)R_{fb} \dots \dots \dots (7)$$

## APPENDIX

### Relationship between $V_{fb}$ and $V_{out}$

The attenuation  $\beta$  of the feedback circuit takes place in two stages : the output signal  $V_{out}$  at the valve anode is attenuated to approximately  $R_{fb}V_{out}/R_l$  appearing across  $R_{fb}$  ; this signal is further attenuated by a factor  $R_{gen}/(R_{gen} + R_{gt})$  to give a voltage  $V_{fb}$  between grid and cathode defined by

$$\begin{aligned} V_{fb} &= \frac{R_{fb}}{R_l} \cdot \frac{R_{gen}}{R_{gen} + R_{gt}} \cdot V_{out} \\ &= \beta_1 (1 - \beta_2) V_{out} \end{aligned}$$

APPENDIX

APPENDIX 7

TABLE OF PRINCIPAL EFFECTS OF NEGATIVE FEEDBACK

Effect on	<i>Voltage-Feedback</i>		<i>Current Feedback</i>		<i>Bridge Feedback</i>
	series-connected	parallel-connected	series-connected	parallel-connected	
Gain	decreased	decreased	decreased	decreased	decreased
Harmonic distortion	decreased	decreased	decreased	decreased	decreased
$r_a$	decreased	decreased	increased	increased	depends on ratio of voltage to current feedback
Input impedance	increased	decreased	increased	decreased	depends whether series- or parallel-connected



## INDEX

- BRIDGE FEEDBACK, 79-91.
- CATHODE FOLLOWER, 55-60, 88-91 :  
Gain, 59.  
Input Impedance, 60.  
Output Impedance, 60.  
Combined Voltage and Current Feedback,  
79.  
Cubic Dynamic Characteristics, 12.  
Current Feedback, 61-78.
- DYNAMIC CHARACTERISTICS, 3.
- ELLIPTICAL LOAD LINES, 21.
- GAIN CONTROL, 38, 67.
- HARMONIC DISTORTION, 3-23.
- INPUT IMPEDANCE, 43, 46, 72, 75.  
Instability, 34, 64.  
Intermodulation, 18.
- NEGATIVE FEEDBACK, 24-103 :  
Current Feedback, 61-78.  
Effect on Attenuation Distortion, 29.  
,, on Gain, 24, 32, 38, 44, 67, 69,  
73, 79.  
Effect on Harmonic Distortion, 27.  
,, on Input Impedance, 43, 46, 72,  
75.  
Effect on Noise, 26.  
,, on Output Impedance, 33, 44, 47,  
63, 73, 75, 81.  
Voltage Feedback, 30-55.
- OUTPUT IMPEDANCE, 33, 44, 47, 63, 73, 75.
- PARABOLIC DYNAMIC CHARACTERISTICS, 4.  
Parallel-connected Current Feedback, 73,  
100.  
Parallel-connected Voltage Feedback, 45,  
85.  
Push-pull, 20.
- SECOND-HARMONIC DISTORTION, 6, 18.  
Series-connected Current Feedback, 69, 96.  
Series-connected Voltage Feedback, 39, 82.
- THIRD-HARMONIC DISTORTION, 16.  
Tone Control, 38, 68.
- VALVE CHARACTERISTICS, 34, 56, 65 :  
With Current Feedback, 65.  
,, Voltage Feedback, 34.  
Of Cathode Follower, 56.
- VOLTAGE FEEDBACK, 30-55